

ASME B16.47-2020
(Revision of ASME B16.47-2017)

Large Diameter Steel Flanges

**NPS 26 Through NPS 60
Metric/Inch Standard**

AN AMERICAN NATIONAL STANDARD



ASME B16.47-2020
(Revision of ASME B16.47-2017)

Large Diameter Steel Flanges

**NPS 26 Through NPS 60
Metric/Inch Standard**

AN AMERICAN NATIONAL STANDARD



**The American Society of
Mechanical Engineers**

Two Park Avenue • New York, NY • 10016 USA

Date of Issuance: January 29, 2021

The next edition of this Standard is scheduled for publication in 2024.

ASME issues written replies to inquiries concerning interpretations of technical aspects of this Standard. Periodically certain actions of the ASME B16 Committee may be published as Cases. Cases and interpretations are published on the ASME website under the Committee Pages at <http://cstools.asme.org/> as they are issued.

Errata to codes and standards may be posted on the ASME website under the Committee Pages to provide corrections to incorrectly published items, or to correct typographical or grammatical errors in codes and standards. Such errata shall be used on the date posted.

The Committee Pages can be found at <http://cstools.asme.org/>. There is an option available to automatically receive an e-mail notification when errata are posted to a particular code or standard. This option can be found on the appropriate Committee Page after selecting "Errata" in the "Publication Information" section.

ASME is the registered trademark of The American Society of Mechanical Engineers.

This code or standard was developed under procedures accredited as meeting the criteria for American National Standards. The Standards Committee that approved the code or standard was balanced to assure that individuals from competent and concerned interests have had an opportunity to participate. The proposed code or standard was made available for public review and comment that provides an opportunity for additional public input from industry, academia, regulatory agencies, and the public-at-large.

ASME does not "approve," "rate," or "endorse" any item, construction, proprietary device, or activity.

ASME does not take any position with respect to the validity of any patent rights asserted in connection with any items mentioned in this document, and does not undertake to insure anyone utilizing a standard against liability for infringement of any applicable letters patent, nor assume any such liability. Users of a code or standard are expressly advised that determination of the validity of any such patent rights, and the risk of infringement of such rights, is entirely their own responsibility.

Participation by federal agency representative(s) or person(s) affiliated with industry is not to be interpreted as government or industry endorsement of this code or standard.

ASME accepts responsibility for only those interpretations of this document issued in accordance with the established ASME procedures and policies, which precludes the issuance of interpretations by individuals.

No part of this document may be reproduced in any form,
in an electronic retrieval system or otherwise,
without the prior written permission of the publisher.

The American Society of Mechanical Engineers
Two Park Avenue, New York, NY 10016-5990

Copyright © 2021 by
THE AMERICAN SOCIETY OF MECHANICAL ENGINEERS
All rights reserved
Printed in U.S.A.

CONTENTS

Foreword	vi
Committee Roster	vii
Correspondence With the B16 Committee	viii
Summary of Changes	x
List of Changes in Record Number Order	xii
1 General	1
2 Pressure–Temperature Ratings	2
3 Component Size: Nominal Pipe Size	3
4 Marking	3
5 Materials	4
6 Dimensions	5
7 Tolerances	6
8 Pressure Testing	7
Mandatory Appendix	
I References	113
Nonmandatory Appendices	
A Methods Used for Establishing Pressure–Temperature Ratings	115
B Gaskets (Other Than Ring-Joint)	119
C Quality System Program	121
D Method for Calculating Bolt Lengths	122
Figures	
1 Welding Ends (Welding Neck Flanges, No Backing Rings)	8
2 Welding Ends (Welding Neck Flanges With Backing Rings)	9
3 Welding Ends (Welding Neck Flanges)	10
D-1 Specified Stud Bolt Length	123
Tables	
1 List of Material Specifications	11
2 List of Bolting Specifications (Applicable ASTM Specifications)	13
3 Pressure–Temperature Ratings for Group 1.1 Materials	14
3C Pressure–Temperature Ratings for Group 1.1 Materials	15
4 Pressure–Temperature Ratings for Group 1.2 Materials	16
4C Pressure–Temperature Ratings for Group 1.2 Materials	17
5 Pressure–Temperature Ratings for Group 1.3 Materials	18
5C Pressure–Temperature Ratings for Group 1.3 Materials	19

6	Pressure–Temperature Ratings for Group 1.4 Materials	20
6C	Pressure–Temperature Ratings for Group 1.4 Materials	21
7	Pressure–Temperature Ratings for Group 1.5 Materials	22
7C	Pressure–Temperature Ratings for Group 1.5 Materials	23
8	Pressure–Temperature Ratings for Group 1.7 Materials	24
8C	Pressure–Temperature Ratings for Group 1.7 Materials	25
9	Pressure–Temperature Ratings for Group 1.9 Materials	26
9C	Pressure–Temperature Ratings for Group 1.9 Materials	27
10	Pressure–Temperature Ratings for Group 1.10 Materials	28
10C	Pressure–Temperature Ratings for Group 1.10 Materials	29
11	Pressure–Temperature Ratings for Group 1.11 Materials	30
11C	Pressure–Temperature Ratings for Group 1.11 Materials	31
12	Pressure–Temperature Ratings for Group 1.13 Materials	32
12C	Pressure–Temperature Ratings for Group 1.13 Materials	33
13	Pressure–Temperature Ratings for Group 1.14 Materials	34
13C	Pressure–Temperature Ratings for Group 1.14 Materials	35
14	Pressure–Temperature Ratings for Group 1.15 Materials	36
14C	Pressure–Temperature Ratings for Group 1.15 Materials	37
15	Pressure–Temperature Ratings for Group 1.17 Materials	38
15C	Pressure–Temperature Ratings for Group 1.17 Materials	39
16	Pressure–Temperature Ratings for Group 1.18 Materials	40
16C	Pressure–Temperature Ratings for Group 1.18 Materials	41
17	Pressure–Temperature Ratings for Group 2.1 Materials	42
17C	Pressure–Temperature Ratings for Group 2.1 Materials	43
18	Pressure–Temperature Ratings for Group 2.2 Materials	44
18C	Pressure–Temperature Ratings for Group 2.2 Materials	45
19	Pressure–Temperature Ratings for Group 2.3 Materials	46
19C	Pressure–Temperature Ratings for Group 2.3 Materials	47
20	Pressure–Temperature Ratings for Group 2.4 Materials	48
20C	Pressure–Temperature Ratings for Group 2.4 Materials	49
21	Pressure–Temperature Ratings for Group 2.5 Materials	50
21C	Pressure–Temperature Ratings for Group 2.5 Materials	51
22	Pressure–Temperature Ratings for Group 2.6 Materials	52
22C	Pressure–Temperature Ratings for Group 2.6 Materials	53
23	Pressure–Temperature Ratings for Group 2.7 Materials	54
23C	Pressure–Temperature Ratings for Group 2.7 Materials	55
24	Pressure–Temperature Ratings for Group 2.8 Materials	56
24C	Pressure–Temperature Ratings for Group 2.8 Materials	57
25	Pressure–Temperature Ratings for Group 2.9 Materials	58
25C	Pressure–Temperature Ratings for Group 2.9 Materials	59
26	Pressure–Temperature Ratings for Group 2.10 Materials	60
26C	Pressure–Temperature Ratings for Group 2.10 Materials	61
27	Pressure–Temperature Ratings for Group 2.11 Materials	62
27C	Pressure–Temperature Ratings for Group 2.11 Materials	63
28	Pressure–Temperature Ratings for Group 2.12 Materials	64

28C	Pressure-Temperature Ratings for Group 2.12 Materials	65
29	Dimensions of Ring-Joint Facings	66
29C	Dimensions of Ring-Joint Facings	67
30	Permissible Imperfections in Flange Facing Finish	68
30C	Permissible Imperfections in Flange Facing Finish	68
31	Dimensions of Class 150 Series A Flanges	69
31C	Dimensions of Class 150 Series A Flanges	71
32	Dimensions of Class 300 Series A Flanges	73
32C	Dimensions of Class 300 Series A Flanges	75
33	Dimensions of Class 400 Series A Flanges	77
33C	Dimensions of Class 400 Series A Flanges	79
34	Dimensions of Class 600 Series A Flanges	81
34C	Dimensions of Class 600 Series A Flanges	83
35	Dimensions of Class 900 Series A Flanges	85
35C	Dimensions of Class 900 Series A Flanges	87
36	Dimensions of Class 75 Series B Flanges	89
36C	Dimensions of Class 75 Series B Flanges	91
37	Dimensions of Class 150 Series B Flanges	93
37C	Dimensions of Class 150 Series B Flanges	95
38	Dimensions of Class 300 Series B Flanges	97
38C	Dimensions of Class 300 Series B Flanges	99
39	Dimensions of Class 400 Series B Flanges	101
39C	Dimensions of Class 400 Series B Flanges	103
40	Dimensions of Class 600 Series B Flanges	105
40C	Dimensions of Class 600 Series B Flanges	107
41	Dimensions of Class 900 Series B Flanges	109
41C	Dimensions of Class 900 Series B Flanges	111
42	Flange Bolting Dimensional Recommendations	112
A-1	Rating Ceiling Values in bar	117
A-2	Rating Ceiling Values in psig	118
B-1	Gasket Groups and Typical Materials	120
D-1	<i>F</i> Values	122
D-2	<i>n</i> Values	123

FOREWORD

In November 1980, a task force was appointed within Subcommittee C of the American National Standards Institute (ANSI) B16 Committee to develop a standard for pipe flanges in sizes NPS 26 through NPS 48. Every attempt was made to standardize those dimensions that existed within the industry for the materials covered by ANSI B16.5.

Prompted by suggestions from committee members, the task force was authorized to increase the size range to NPS 60. The first draft was developed in December 1982 to include Class 75 through Class 1500 for the size range NPS 26 through NPS 60. Flange dimensions were based on the Manufacturers Standardization Society, Standard Practice (MSS SP) 44 flanges, except for Class 75 flanges that are ANSI/API 605 flanges.

At the request of the American Petroleum Institute (API), flange dimensions, in accordance with the API Standard 605, were included in the subsequent drafts. Class 1500 flanges were deleted due to a lack of interest in using large-size flanges in that pressure-temperature rating.

The API 605 flanges for Classes 150 and 300 and for sizes NPS 36 and smaller for classes higher than Class 300 are not compatible with the MSS SP-44 flanges. Thus, the MSS SP-44 flanges are designated as Series A flanges, and the API 605 flanges are designated as Series B flanges in this Standard. Materials covered in this Standard are as in ANSI B16.5, except nickel base alloys are excluded. Pressure-temperature ratings are in accordance with ANSI B16.5.

In 1982, American National Standards Committee B16 was reorganized as the American Society of Mechanical Engineers (ASME) B16 Committee operating under procedures accredited by ANSI. Following approval by the Standards Committee and ASME, approval as an American National Standard was given by ANSI on June 12, 1990.

The 1996 edition allowed flanges marked with more than one material grade or specification, revised flange face finish requirements, revised pressure-temperature ratings for several material groups, added permissible flange facing imperfections, added blind flanges for Series B flanges, and included several other revisions. Following approval by the Standards Committee and ASME Boiler and Pressure Vessel Committee, ANSI approved the 1996 edition as an American National Standard on October 3, 1996, with the new designation ASME B16.47-1996.

In 2006, several revisions were made, including use of metric units as primary units, with U.S. Customary units in either parenthetical or separate forms. [Mandatory Appendix I](#) was provided after the main text for convenience to cover ratings and dimensions in U.S. Customary units. Inch dimension bolt holes were retained for flanges manufactured to metric dimensions to avoid fit-up problems. Development of metric dimensions was done to reflect the intended precision of the dimension rather than by numerical conversion. For some materials, pressure-temperature ratings were revised to reflect revisions to material strength properties (tensile and yield) listed in the ASME Boiler and Pressure Vessel Code, Section II. Some materials were assigned to different rating tables in order to minimize changes to ratings for commonly used materials. Following the approvals of the Standards Committee and ASME, approval for the revised edition was granted by ANSI on November 6, 2006.

In the 2011 edition, the References section was revised to cover the requirements of material specification editions other than those listed in [Mandatory Appendix III](#). Following approval by the Standards Committee and the ASME Board on PTCS, the 2011 edition was approved as an American National Standard by ANSI on August 17, 2011, with the new designation ASME B16.47-2011.

In the 2017 edition, pressure-temperature ratings for Group 1.18 materials were revised at 650°C (1,200°F). A reference was made to MSS SP-44 for some classes of flanges made with materials having a high yield strength. A forging requirement was made explicit, and references were updated. Following approval by the ASME B16 Standards Committee, the 2017 edition was approved by ANSI as an American National Standard on March 6, 2017, with the new designation ASME B16.47-2017.

In ASME B16.47-2020, the U.S. Customary tables formerly in [Mandatory Appendix I](#) have been relocated to the main text and redesignated with a "C" suffix (e.g., Table I-1 is now [Table 3C](#)). Former [Mandatory Appendix I](#) has been deleted, and the subsequent [Mandatory Appendix](#) has been redesignated. Cross-references have been updated accordingly. In addition, this edition includes a new [Nonmandatory Appendix D](#) and new language describing ASME Cases, and bolt lengths have been added to the dimension tables. Following approval by the ASME B16 Standards Committee, this revision to the 2017 edition was approved by ANSI as an American National Standard on November 13, 2020, with the new designation ASME B16.47-2020.

ASME B16 COMMITTEE

Standardization of Valves, Flanges, Fittings, and Gaskets

(The following is the roster of the Committee at the time of approval of this Standard.)

STANDARDS COMMITTEE OFFICERS

C. E. Davila, *Chair*
R. M. Bojarczuk, *Vice Chair*
C. Ramcharran, *Secretary*

STANDARDS COMMITTEE PERSONNEL

A. Appleton , Alloy Stainless Products Co., Inc.	T. A. McMahon , Emerson Process Management
J. E. Barker , DeZURIK, Inc.	R. C. Merrick , Fluor Enterprises
R. W. Barnes , ANRIC Enterprises, Inc.	W. H. Patrick , The Dow Chemical Co.
D. C. Bayreuther , Neles Corp.	D. W. Raho , CCM 2000
W. B. Bedesem , Consultant	C. Ramcharran , The American Society of Mechanical Engineers
R. M. Bojarczuk , ExxonMobil Research and Engineering Co.	D. F. Reid , VSP Technologies
A. M. Cheta , Qatar Shell GTL	R. A. Schmidt , Canadoil
M. A. Clark , Consultant	J. Sekerak , CSA Group
G. A. Cuccio , Capitol Manufacturing Co.	J. P. Tucker , Flowserve
J. D'Avanzo , Fluoroseal Valves	F. R. Volgstadt , Volgstadt and Associates, Inc.
C. E. Davila , Crane ChemPharma and Energy	F. Feng , <i>Delegate</i> , China Productivity Center for Machinery
K. S. Felder , Valero Energy	J. D. Grant , <i>Alternate</i> , DeZURIK, Inc.
D. R. Frikken , Becht Engineering Co., Inc.	P. V. Craig , <i>Contributing Member</i> , Jomar Group
J. R. Holstrom , Val-Matic Valve and Manufacturing Corp.	B. G. Fabian , <i>Contributing Member</i> , Pennsylvania Machine Works
D. Hunt, Jr. , Fastenal	A. G. Kireta, Jr. , <i>Contributing Member</i> , Copper Development Association, Inc.
G. A. Jolly , Samshin, Ltd.	
E. J. Lain , Exelon Nuclear	

SUBCOMMITTEE C — STEEL FLANGES AND FLANGED FITTINGS

A. M. Cheta , <i>Chair</i> , Qatar Shell GTL	J. R. Holstrom , Val-Matic Valve and Manufacturing Corp.
A. Carrion , <i>Secretary</i> , The American Society of Mechanical Engineers	G. A. Jolly , Samshin, Ltd.
A. Appleton , Alloy Stainless Products Co., Inc.	R. C. Merrick , Fluor Enterprises
W. B. Bedesem , Consultant	W. H. Patrick , The Dow Chemical Co.
C. E. Davila , Crane ChemPharma and Energy	D. W. Raho , CCM 2000
B. Dennis , Kerkau Manufacturing	T. V. Ramakrishnan , Forged Components, Inc.
J. G. Dominguez , Welding Outlets, Inc.	R. A. Schmidt , Canadoil
J. P. Ellenberger , Retired	D. E. Tezzo , Emerson
D. R. Frikken , Becht Engineering Co., Inc.	J. A. Tubb , JCM Industries, Inc.
E. Gulgun , International Standard Valve, Inc.	J. P. Tucker , Flowserve
G. B. Hailegiorgis , AFGlobal	G. T. Walden , Ferguson
M. M. Haynie , Bechtel	M. M. Zaidi , Worley

CORRESPONDENCE WITH THE B16 COMMITTEE

General. ASME Standards are developed and maintained with the intent to represent the consensus of concerned interests. As such, users of this Standard may interact with the Committee by requesting interpretations, proposing revisions or a case, and attending Committee meetings. Correspondence should be addressed to:

Secretary, B16 Standards Committee
The American Society of Mechanical Engineers
Two Park Avenue
New York, NY 10016-5990
<http://go.asme.org/Inquiry>

Proposing Revisions. Revisions are made periodically to the Standard to incorporate changes that appear necessary or desirable, as demonstrated by the experience gained from the application of the Standard. Approved revisions will be published periodically.

The Committee welcomes proposals for revisions to this Standard. Such proposals should be as specific as possible, citing the paragraph number(s), the proposed wording, and a detailed description of the reasons for the proposal, including any pertinent documentation.

Proposing a Case. Cases may be issued to provide alternative rules when justified, to permit early implementation of an approved revision when the need is urgent, or to provide rules not covered by existing provisions. Cases are effective immediately upon ASME approval and shall be posted on the ASME Committee web page.

Requests for Cases shall provide a Statement of Need and Background Information. The request should identify the Standard and the paragraph, figure, or table number(s), and be written as a Question and Reply in the same format as existing Cases. Requests for Cases should also indicate the applicable edition(s) of the Standard to which the proposed Case applies.

Interpretations. Upon request, the B16 Standards Committee will render an interpretation of any requirement of the Standard. Interpretations can only be rendered in response to a written request sent to the Secretary of the B16 Standards Committee.

Requests for interpretation should preferably be submitted through the online Interpretation Submittal Form. The form is accessible at <http://go.asme.org/InterpretationRequest>. Upon submittal of the form, the Inquirer will receive an automatic e-mail confirming receipt.

If the Inquirer is unable to use the online form, he/she may e-mail the request to the Secretary of the B16 Standards Committee at SecretaryB16@asme.org, or mail it to the above address. The request for an interpretation should be clear and unambiguous. It is further recommended that the Inquirer submit his/her request in the following format:

- Subject: Cite the applicable paragraph number(s) and the topic of the inquiry in one or two words.
- Edition: Cite the applicable edition of the Standard for which the interpretation is being requested.
- Question: Phrase the question as a request for an interpretation of a specific requirement suitable for general understanding and use, not as a request for an approval of a proprietary design or situation. Please provide a condensed and precise question, composed in such a way that a “yes” or “no” reply is acceptable.
- Proposed Reply(ies): Provide a proposed reply(ies) in the form of “Yes” or “No,” with explanation as needed. If entering replies to more than one question, please number the questions and replies.
- Background Information: Provide the Committee with any background information that will assist the Committee in understanding the inquiry. The Inquirer may also include any plans or drawings that are necessary to explain the question; however, they should not contain proprietary names or information.

Requests that are not in the format described above may be rewritten in the appropriate format by the Committee prior to being answered, which may inadvertently change the intent of the original request.

Moreover, ASME does not act as a consultant for specific engineering problems or for the general application or understanding of the Standard requirements. If, based on the inquiry information submitted, it is the opinion of the Committee that the Inquirer should seek assistance, the inquiry will be returned with the recommendation that such assistance be obtained.

ASME procedures provide for reconsideration of any interpretation when or if additional information that might affect an interpretation is available. Further, persons aggrieved by an interpretation may appeal to the cognizant ASME Committee or Subcommittee. ASME does not “approve,” “certify,” “rate,” or “endorse” any item, construction, proprietary device, or activity.

Attending Committee Meetings. The B16 Standards Committee regularly holds meetings and/or telephone conferences that are open to the public. Persons wishing to attend any meeting and/or telephone conference should contact the Secretary of the B16 Standards Committee.

ASME B16.47-2020

SUMMARY OF CHANGES

Following approval by the ASME B16 Standards Committee and ASME, and after public review, ASME B16.47-2020 was approved by the American National Standards Institute on November 13, 2020.

In ASME B16.47-2020, the U.S. Customary tables formerly in Mandatory Appendix I have been relocated to the main text and redesignated with a “C” suffix (e.g., Table I-1 is now Table 3C). Former Mandatory Appendix I has been deleted, and the subsequent Mandatory Appendix has been redesignated. Cross-references have been updated accordingly. In addition, this edition includes the following changes identified by a margin note, **(20)**. The Record Numbers listed below are explained in more detail in the “List of Changes in Record Number Order” following this Summary of Changes.

<i>Page</i>	<i>Location</i>	<i>Change (Record Number)</i>
1	1	Title revised (18-869)
1	1.1	Title revised (18-869)
2	1.12	Added (18-869)
4	4.2.9	Added (18-869)
5	6.1.1	Revised (19-1684)
6	6.5.2	Added and subsequent paragraph redesignated (18-1108)
6	7.1	Subparagraphs (a) and (b) revised (19-1684)
6	7.2	In-text table revised (19-1684)
6	7.3.1	Revised (19-1684)
6	7.3.2	Subparagraphs (a) and (b) revised (19-1684)
7	7.4	Revised (19-1684)
8	Figure 1	U.S. Customary values added
9	Figure 2	U.S. Customary values added
10	Figure 3	U.S. Customary values added
11	Table 1	For Material Group 1.15, "Forgings" entry revised (20-887)
36	Table 14	(1) Forgings material revised (20-887) (2) For 600°C, 625°C, and 650°C, working pressures revised (20-887)
37	Table 14C	(1) Forgings material revised (20-887) (2) For 1,100°F, 1,150°F, and 1,200°F, working pressures revised (20-887)
66	Table 29	Tolerances revised (18-1108)
67	Table 29C	Tolerances revised (18-1108)
68	Table 30	Revised
68	Table 30C	Former Table I-28 revised
69	Table 31	Revised
71	Table 31C	Former Table I-29 revised
73	Table 32	Revised
75	Table 32C	Former Table I-30 revised
77	Table 33	Revised
79	Table 33C	Former Table I-31 revised

<i>Page</i>	<i>Location</i>	<i>Change (Record Number)</i>
81	Table 34	Revised
83	Table 34C	Former Table I-32 revised
85	Table 35	Revised
87	Table 35C	Former Table I-33 revised
89	Table 36	Revised
91	Table 36C	Former Table I-34 revised
93	Table 37	Revised
95	Table 37C	Former Table I-35 revised
97	Table 38	Revised
99	Table 38C	Former Table I-36 revised
101	Table 39	Revised
103	Table 39C	Former Table I-37 revised
105	Table 40	Revised
107	Table 40C	Former Table I-38 revised
109	Table 41	Revised
111	Table 41C	Former Table I-39 revised
112	Table 42	Spelling of “coarse” corrected by errata
113	Mandatory Appendix I	References updated
122	Nonmandatory Appendix D	Added (18-1108)

LIST OF CHANGES IN RECORD NUMBER ORDER

<u>Record Number</u>	<u>Change</u>
14-2169	Revised para. 5.3.4 to reference para. 5.4.2 and Nonmandatory Appendix B.
17-655	Revised General Note (g) in Tables 31 through 41 (Tables 31C through 41C) to address reducing flanges or pressure taps made in blind flanges for testing, vents, or drains.
18-869	Revised titles of Section 1 and para. 1.1 and added new paras. 1.12 and 4.2.9 to provide guidance on ASME Cases.
18-1108	Added new para. 6.5.2 and Nonmandatory Appendix D so that information on minimum bolt length matches that in ASME B16.5.
19-1684	Revised metric dimensions to align with U.S. Customary dimensions.
20-887	Revised Tables 1 and 14 (14C) to add a material nomenclature change from A182 Gr. F91 to A182 Gr. F91 Type 1.

LARGE DIAMETER STEEL FLANGES

NPS 26 Through NPS 60

Metric/Inch Standard

(20) **1 GENERAL**

(20) **1.1 Scope**

This Standard covers pressure–temperature ratings, materials, dimensions, tolerances, marking, and testing for pipe flanges in sizes NPS 26 through NPS 60. Included are flanges with rating class designations 75, 150, 300, 400, 600, and 900 with requirements given in both SI (Metric) and U.S. Customary units, with diameter of bolts and flange bolt holes expressed in inch units.

This Standard is limited to

- (a) flanges made from cast or forged materials
- (b) blind flanges made from cast, forged, or plate materials (see [Tables 1](#) and [2](#))

Also included in this Standard are requirements and recommendations regarding flange bolting, flange gaskets, and flange joints.

1.2 Flange Series

This Standard provides two series of flange dimensions. Series A specifies flange dimensions for general use flanges. Series B specifies flange dimensions for compact flanges that, in most cases, have smaller bolt circle diameters than Series A flanges. These two series of flanges are, in general, not interchangeable. The user should recognize that some flanged valves, equipment bolted between flanges, and flanged equipment may be compatible with only one series of these flanges.

1.3 References

Codes, standards, and specifications, containing provisions to the extent referenced herein, constitute requirements of this Standard. These references are listed in [Mandatory Appendix I](#).

1.4 Time of Purchase, Manufacture, or Installation

The pressure–temperature ratings in this Standard are applicable upon its publication to all flanges within its scope that otherwise meet its requirement. For unused flanges maintained in inventory, the manufacturer of the flange may certify conformance to this edition, provided that it can be demonstrated that all require-

ments of this edition have been met. Where such components were installed in accordance with the pressure–temperature ratings of an earlier edition of this Standard, those ratings are applicable, except as may be governed by the applicable code or regulation.

1.5 User Accountability

This Standard cites responsibilities that are to be assumed by the flange user in the areas of, for example

- (a) application
- (b) installation
- (c) system pressure testing
- (d) operation
- (e) material selection

1.6 Quality Systems

Requirements relating to the product manufacturer's quality system program are described in [Nonmandatory Appendix C](#).

1.7 Relevant Units

This Standard states values in both SI (Metric) and U.S. Customary units. As an exception, diameter of bolts and flange bolt holes are expressed in inch units only. These systems of units are to be regarded separately as standard. Within the text, the U.S. Customary units are shown in parentheses. The values stated in each system are not exact equivalents; therefore, it is required that each system of units be used independently of the other. Except for diameter of bolts and flange bolt holes, combining values from the two systems constitutes nonconformance with the Standard.

1.8 Selection of Materials

Criteria for selection of materials suitable for particular fluid service are not within the scope of this Standard.

1.9 Convention

For determining conformance with this Standard, the convention for fixing significant digits where limits (maximum and minimum values) are specified shall be as defined in ASTM Practice E29. This requires that an observed or calculated value be rounded off to the

nearest unit in the last right-hand digit used for expressing the limit. Decimal values and tolerances do not imply a particular method of measurement.

1.10 Denotation

1.10.1 Pressure Rating Designation. Class, followed by a dimensionless number, is the designation for pressure-temperature ratings (i.e., Class 75, Class 150, Class 300, Class 400, Class 600, Class 900).

1.10.2 Size. NPS, followed by a dimensionless number, is the designation for nominal flange size. NPS is related to the reference nominal diameter, DN, used in international and other standards. For the sizes covered in this Standard, the relationship is $DN = 25 \times NPS$.

1.11 Similar Flanges

MSS SP-44 covers similar Class 150, 300, 400, 600, and 900 flanges for use with high strength pipe made from materials having yield strength greater than 276 MPa (40,000 psi) resulting in large inside pipe diameter and thinner pipe wall. See [para. 2.7](#).

(20) 1.12 Cases

ASME issues Cases that are applicable to this Standard by, for example, adding new materials or alternative construction requirements. The Cases

- (a) modify the requirements of this Standard
- (b) are applicable from their issue dates until the Cases are annulled
- (c) may be used only when agreed to by the purchaser and the manufacturer, and when so agreed, the marking shall include the Case number

2 PRESSURE-TEMPERATURE RATINGS

2.1 General

Pressure-temperature ratings are maximum allowable working gage pressures, in bar units, at the temperatures in degrees Celsius shown in [Tables 3](#) through [28](#) for the applicable material and class designation. [Tables 3C](#) through [28C](#) list pressure-temperature ratings using pounds per square inch (psi) units for pressure at the temperature in degrees Fahrenheit. For intermediate temperatures, linear interpolation is permitted. Interpolation between class designations is not permitted.

2.2 Flanged Joints

A flanged joint is composed of separate and independent, although interrelated, components: the flanges, the gasket, and the bolting, which are assembled by another influence, the assembler. Proper controls must be exercised in the selection and application for all of these elements to attain a joint that has acceptable leak tight-

ness. Assembly and tightening techniques, such as controlled bolt tightening, are described in ASME PCC-1.

2.3 Ratings of Flanged Joints

2.3.1 Basis. Pressure-temperature ratings apply to flanged joints that conform to the limitations on bolting in [para. 5.3](#) and on gaskets in [para. 5.4](#), and that are made up in accordance with good practice for alignment and assembly (see [para. 2.2](#)). Use of these ratings for flanged joints not conforming to these limitations is the responsibility of the user.

2.3.2 Mixed Flanged Joints. If the two flanges in a flanged joint do not have the same pressure-temperature rating, the rating of the joint at any temperature is the lower of the two flange ratings at that temperature.

2.4 Rating Temperature

The temperature shown for a corresponding pressure rating is the temperature of the pressure-containing shell of the component. In general, this temperature is the same as that of the contained fluid. Use of a pressure rating corresponding to a temperature other than that of the contained fluid is the responsibility of the user, subject to the requirements of applicable codes and regulations. For any temperature below -29°C (-20°F), the rating shall be no greater than the rating shown for -29°C (-20°F). See also [para. 2.5.3](#).

2.5 Temperature Considerations

2.5.1 General. Use of flanges at either high or low temperatures shall take into consideration the risk of joint leakage due to forces and moments developed in the connected piping or equipment. Provisions in [paras. 2.5.2](#) and [2.5.3](#) are included as advisory with the aim of lessening these risks.

2.5.2 High Temperature. Application at temperatures in the creep range will result in decreasing bolt loads as relaxation of flanges, bolts, and gaskets takes place. Flanged joints subjected to thermal gradients may likewise be subject to decreasing bolt loads. Decreased bolt loads diminish the capacity of the flanged joint to sustain loads effectively without leakage. At temperatures above 200°C (400°F) for Classes 75 and 150, and above 400°C (750°F) for other class designations, flanged joints may develop leakage problems unless care is taken to avoid imposing severe external loads and/or severe thermal gradients.

2.5.3 Low Temperature. Some of the materials listed in [Tables 1](#) and [2](#), notably some carbon steels, may undergo a decrease in ductility when used at low temperatures to such an extent as to be unable to safely resist shock loading, sudden changes of stress, or high stress concentration. Some codes or regulations may require impact testing for applications even where temperatures are

higher than -29°C (-20°F). When such requirements apply, it is the responsibility of the user to ensure these requirements are communicated to the manufacturer prior to the time of purchase.

2.6 System Pressure Testing

Flanged joints may be subjected to system pressure tests at a pressure of 1.5 times the 38°C (100°F) rating rounded off to the next higher 1 bar (25 psi) increment. Testing at any higher pressure is the responsibility of the user, taking into account the requirements of the applicable code or regulation.

2.7 Welding Neck Flanges

2.7.1 Maximum Bore Size. Ratings for welding neck flanges covered by this Standard are based upon their hubs at the welding end having a thickness at least equal to that calculated for pipe having a 276 MPa (40,000 psi) specified minimum yield strength. To ensure adequate flange hub thickness for flange sizes NPS 26 and larger, the bore of a welding neck flange, dimension B as shown in Figures 1 and 2, shall not exceed B_{\max} determined as follows:

Class	B_{\max}
75	0.9971A
150	0.9942A
300	0.9850A
400	0.9800A
600	0.9700A
900	0.9550A

A = tabulated hub diameter, beginning of chamfer as listed in the dimensional tables

B_{\max} = maximum permissible diameter for the bore of a welding neck flange

The resultant units for diameter B_{\max} are the same as those entered for diameter A .

2.7.2 Components of Unequal Strength. The tabulated ratings for welding neck flanges are independent of components of unequal strength or unequal wall thickness to which they may be attached. For all attachments, the pressure rating of the flange shall not be exceeded.

2.7.3 Attachment Welds. Attachment welds should be made in accordance with the applicable code or regulation. See para. 6.4 and Figure 3 for weld end dimensional requirements.

2.8 Multiple Material Grades

Materials for flanges may meet the requirements of more than one specification or the requirements of more than one grade of a specification listed in Table 1. In either case, the pressure-temperature

ratings for any of these specifications or grades may be used provided that the material is marked in accordance with para. 4.2.8.

3 COMPONENT SIZE: NOMINAL PIPE SIZE

As applied in this Standard, the use of the phrase “nominal pipe size” or the designation NPS followed by a dimensionless number is for the purpose of pipe or flange end connection size identification. The number is not the same as the flange inside diameter.

4 MARKING

4.1 General

Except as noted in para. 4.2, flanges shall be marked as required in MSS SP-25.

4.2 Identification Markings

4.2.1 Name. The manufacturer’s name or trademark shall be applied.

4.2.2 Materials. Materials shall be identified in the following ways:

(a) Cast flanges shall be marked with the ASTM specification,¹ grade identification symbol (letters and numbers), and the melt number or melt identification.

(b) Plate flanges and forged flanges shall be marked with the ASTM specification¹ number and grade identification symbol.

(c) A manufacturer may supplement these mandatory material markings with a trade designation for the material grade, but confusion of symbols shall be avoided.

(d) For flanges manufactured from material that meets the requirements for more than one specification or grade of a specification listed in Table 1, see para. 4.2.8.

4.2.3 Rating Designation. The flange shall be marked with the number that corresponds to its pressure rating class designation (i.e., 75, 150, 300, 400, 600, or 900).

4.2.4 Conformance. The designation B16 or B16.47 shall be applied to the flange, preferably adjacent to the class designation, to indicate conformance to this Standard. The use of the prefix “ASME” is optional.

4.2.5 Temperature. Temperature markings are not required on flanges. However, if marked, the temperature shall be shown with its corresponding tabulated pressure rating for the material.

4.2.6 Size. The NPS identification number shall be marked on flanges.

¹ An ASME Boiler and Pressure Vessel Code, Section II specification number may be substituted for an ASTM specification number provided the requirements of the ASME specifications are identical or more stringent than the ASTM specification for the Grade, Class, or Type of material.

4.2.7 Ring-Joint Flange. The edge (periphery) of each ring-joint flange shall be marked with the letter R and the corresponding ring-groove number.

4.2.8 Multiple Material Marking. Material for components that meet the requirements for more than one ASTM specification number or grade of a specification listed in Table 1 may, at the manufacturer's option, be marked with more than one of the applicable specification numbers or grade symbols. These identification markings shall be placed so as to avoid confusion in identification. The multiple marking shall be in accordance with the guidelines set out in ASME Boiler and Pressure Vessel Code, Section II, Part D, Appendix 7.

- (20) **4.2.9 Case Number.** When a flange or flanged fitting meets the requirements of a Case, the Case number shall be included in the markings as "Case ##".

5 MATERIALS

5.1 General

(a) Materials required for flanges are listed in Table 1 with the restriction that plate materials shall be used only for blind flanges. Flanges shall be manufactured as one piece in accordance with the applicable material specification. Assembly of multiple pieces into the finished product by welding or other means is not permitted by this Standard.

(b) Each forged flange shall be finished from a part that is brought as nearly as practicable to the finished shape and size by a compressive plastic hot working operation that consolidates the material to produce an essentially wrought structure, and shall be so processed during the operation as to cause metal flow in the direction most favorable for resisting the stresses encountered in service.

(c) Recommended bolting materials are listed in Table 2 (see para. 5.3).

(d) Corresponding materials listed in the ASME Boiler and Pressure Vessel Code, Section II may be used provided that the requirements of the ASME specification are identical or more stringent than the ASTM specification for the Grade, Class, or Type of material.

5.1.1 Application. Criteria for the selection of materials are not within the scope of this Standard. The possibility of material deterioration in service should be considered by the user. Carbide phase conversion to graphite and excessive oxidation of ferritic materials, susceptibility to intergranular corrosion of austenitic materials, or grain boundary attack of nickel base alloys are among those items requiring attention. A detailed discussion of precautionary considerations can be found in

(a) ASME B31.3, Appendix F

(b) ASME Boiler and Pressure Vessel Code Section II, Part D, Appendix 6

(c) ASME Boiler and Pressure Vessel Code Section III, Division 1, Appendix W

5.1.2 Responsibility. When service conditions dictate the implementation of special material requirements [e.g., using a Group 2 material above 538°C (1,000°F)], it is the user's responsibility to so specify to the manufacturer to ensure compliance with metallurgical requirements listed in the notes in Tables 3 through 28 (Tables 3C through 28C).

5.1.3 Cast Surfaces. Cast surfaces of flange pressure boundaries shall be in accordance with MSS SP-55, except that all Type I defects are unacceptable, and defects in excess of Plates "a" and "b" for Type II through Type XII are unacceptable.

5.2 Mechanical Properties

Mechanical properties shall be obtained from test specimens that represent the final heat-treated condition of the material required by the material specification.

5.3 Bolting

5.3.1 General. Bolting listed in Table 2 is recommended for use with flanges covered by this Standard. Bolting of other material may be used if permitted by the applicable code or government regulation. Bolting materials are subject to the limitations given in paras. 5.3.2 through 5.3.5.

5.3.2 High Strength Bolting. Bolting materials having allowable stresses not less than those for ASTM A193 Gr. B7 are listed as high strength in Table 2. These and other materials of comparable strength may be used in any flanged joint.

5.3.3 Intermediate Strength Bolting. When bolting materials listed as intermediate strength in Table 2 or other bolting of comparable strength are used in a flanged joint, it is recommended that the user verify the ability of the selected bolting to seat the selected gasket and maintain a leak-tight joint under expected operating condition.

5.3.4 Low Strength Bolting. Bolting materials having no more than 206 MPa (30,000 psi) specified minimum yield strength are listed as low strength in Table 2. These materials and others of comparable strength are to be used only in Classes 75, 150, and 300 flanged joints (see para. 5.4.2 and Nonmandatory Appendix B). Flanged assemblies using low strength carbon steel bolts should not be used above 200°C (400°F) or below -29°C (-20°F).

5.3.5 Bolting to Gray Iron Flanges. The following recommendations are made in recognition of the low ductility of gray iron:

(a) Alignment of flange faces is essential, along with control of assembly bolt torque, so as not to overstress gray iron flanges. Care must also be exercised to ensure that piping loads transmitted to gray iron flanges are controlled, taking into account its lack of ductility, and recognizing that gray iron flanges should not be used where suddenly applied loads such as rapid pressure fluctuation may occur.

(b) Where Class 150 steel flanges are bolted to Class 125 gray iron flanges, the gaskets should be made of Group No. 1a materials (see [Nonmandatory Appendix B, Table B-1](#)) and both flanges should have flat faces and either of the following:

(1) Low strength bolting within the limitations of [para. 5.3.4](#) should be used with ring gaskets extending to the bolt holes.

(2) Bolting of low ([para. 5.3.4](#)), intermediate ([para. 5.3.3](#)), or high ([para. 5.3.2](#)) strength may be used with full face gaskets extending to the outside diameters of the flanges.

(c) Where Class 300 steel flanges are bolted to Class 250 gray iron flanges, the gaskets should be made of Group No. 1a materials (see [Nonmandatory Appendix B, Table B-1](#)) and either of the following:

(1) Low strength bolting within the limitations of [para. 5.3.4](#) should be used with gaskets extending to the bolt holes and with flanges having either raised or flat faces.

(2) Bolting of low ([para. 5.3.4](#)), intermediate ([para. 5.3.3](#)), or high ([para. 5.3.2](#)) strength may be used with full face gaskets extending to the outside diameters of the flanges and with both the Class 300 steel and Class 250 gray iron flanges having flat faces.

5.4 Gaskets

5.4.1 General. Ring-joint gasket materials shall conform to ASME B16.20. Materials for other gaskets are described in [Nonmandatory Appendix B](#). The user is responsible for the selection of gasket materials that will withstand the expected bolt loading without injurious crushing and are suitable for the service conditions.

5.4.2 Gaskets for Low Strength Bolting. If bolting listed as low strength in [Table 2](#) is used, gaskets shown in [Nonmandatory Appendix B, Table B-1](#), Group No. 1a are recommended.

5.4.3 Gaskets for Class 150 Flanged Joints. It is recommended that only Group No. 1a or Group No. 1b gaskets from [Nonmandatory Appendix B, Table B-1](#) be used for Class 150 flanged joints.

5.4.4 Gaskets for Class 75 Flanged Joints. It is recommended that only Group No. 1a gaskets from [Nonmandatory Appendix B, Table B-1](#), with a gasket factor $m = 2$ or less and minimum design seating stress $y = 1,600$ psi or less, be used. The m and y

factors are those given in Appendix 2 of the ASME Boiler and Pressure Vessel Code, Section VIII, Division 1.

6 DIMENSIONS

6.1 Flange Facings

6.1.1 General. Classes 75, 150, and 300 flanges are regularly furnished with a 1.5 mm (0.06 in.) raised face. Classes 400, 600, and 900 flanges are regularly furnished with a 6.4 mm (0.25 in.) raised face. The thickness of the raised face in all cases is in addition to the minimum flange thickness, t_f . It is recommended that the Class 75 flanges be used only with a 1.5 mm (0.06 in.) raised face or flat face. Dimensions for ring-joint facing are given in [Table 29 \(Table 29C\)](#) for Series A flanges. (20)

6.1.1.1 Raised Face Flanges. The raised face thickness shall be in addition to the minimum flange thickness, t_f .

6.1.1.2 Ring-Joint Flanges. The thickness required to form the ring-joint groove [dimension E in [Table 29 \(Table 29C\)](#)] shall be in addition to the minimum flange thickness, t_f .

6.1.2 Blind Flanges. Blind flanges need not be faced in the center if, when this center part is raised, its diameter is at least 25 mm (1 in.) smaller than the mating pipe inside diameter. When the center part is depressed, its diameter shall not be greater than the inside diameter of the mating flange. Machining of the depressed center is not required.

6.1.3 Flat Face Flanges. The raised face may be removed by the user from a raised face flange to convert it to a flat face flange.

6.1.4 Flange Facing Finish. Flange facing finishes shall be in accordance with [paras. 6.1.4.1](#) and [6.1.4.2](#), except that other finishes may be furnished by agreement between the user and the manufacturer. The finish of the gasket contact faces shall be judged by visual comparison with Ra standards (see ASME B46.1) and not by instruments having stylus tracers and electronic amplification.

6.1.4.1 Ring-Joint. The side wall surface finish of the gasket groove shall not exceed $1.6 \mu\text{m}$ (63 $\mu\text{in.}$) roughness.

6.1.4.2 Other Flange Facings. Either a serrated concentric or serrated spiral finish having a resultant surface finish from $3.2 \mu\text{m}$ to $6.3 \mu\text{m}$ (125 $\mu\text{in.}$ to 250 $\mu\text{in.}$) average roughness shall be furnished. The cutting tool employed should have an approximate 1.5 mm (0.06 in.) or larger radius, and there should be from 1.8 grooves/mm through 2.2 grooves/mm (45 grooves/in. through 55 grooves/in.).

6.1.5 Flange Facing Finish Imperfections. Imperfections in the flange facing finish shall not exceed the dimensions shown in [Table 30 \(Table 30C\)](#). Adjacent

imperfections shall be separated by a distance of at least 4 times the maximum radial projection. A radial projection shall be measured by the difference between an outer radius and an inner radius encompassing the imperfection where the radii are struck from the centerline of the bore. Imperfections less than half the depth of the serrations shall not be considered cause for rejection. Protrusions above the serrations are not permitted.

6.2 Flange Bolt Holes

Bolt holes are in multiples of four. Bolt holes shall be equally spaced.

6.3 Bolting Bearing Surfaces

Flanges shall have bearing surfaces for bolting that are parallel to the flange face within 1 deg. Back facing or spot facing shall not reduce the flange thickness below the dimensions t_f given in [Tables 31 through 41 \(Tables 31C through 41C\)](#). Spot facing or back facing shall be in accordance with MSS SP-9.

6.4 Welding End Preparation for Welding Neck Flanges

6.4.1 Illustrations. Welding ends are illustrated in [Figures 1 through 3](#).

6.4.2 Bores. Cylindrical bores shown in [Figure 1](#) are standard unless specifically ordered to suit the special conditions illustrated in [Figures 2 and 3](#). See [para. 2.7](#) for maximum bore sizes.

6.5 Flange Bolting Dimensions

6.5.1 Dimensional Standards. Stud bolts, threaded at both ends or threaded full length, or bolts may be used in flange joints. Dimensional recommendations for bolts, stud bolts, and nuts are shown in [Table 42](#). See [para. 5.3](#) for bolting material recommendations.

(20) **6.5.2 Bolt Lengths.** Stud bolt lengths, including the height of two heavy hexagon nuts, are shown as dimension L in [Tables 31 through 41 \(Tables 31C through 41C\)](#). The tabulated stud bolt length L does not include the height of end points. An end point is defined as an unthreaded length, such as a chamfer, which extends beyond the thread. The method of calculating bolt lengths is explained in [Nonmandatory Appendix D](#). The tabulated bolt lengths are reference dimensions. Users may select other bolting lengths.

Tabulated values shown are for bolting together two welding neck flanges only. Other types of flanges, including blind flanges, may require different bolt lengths.

6.5.3 Bolting Recommendations. For flange joints, stud bolts with a nut at each end are recommended for all applications.

6.6 Gaskets

6.6.1 Ring-Joint Gaskets. Ring-joint gasket dimensions should conform to ASME B16.20.

6.6.2 Nonmetallic Gaskets. Nonmetallic gasket dimensions should conform to ASME B16.21.

6.6.3 Spiral Wound and Double-Jacketed Gaskets. Spiral wound and double-jacketed corrugated metal gaskets should conform to ASME B16.20.

6.7 Hub Dimensions

Any modification to hub dimensions shown in [Tables 31 through 41 \(Tables 31C through 41C\)](#) shall be by agreement between the purchaser and manufacturer and shall be confirmed by calculations in accordance with ASME Boiler and Pressure Vessel Code, Section VIII, Division 1, Appendix 2. Flanges so modified shall be marked with the material designation of the pipe to which they are to be welded in addition to the marking per [para. 4.2.2](#).

7 TOLERANCES

7.1 Facings

(20)

Required tolerances for various flange facings are as follows:

- (a) outside diameter of raised face, ± 2 mm (± 0.08 in.)
- (b) 1.5 mm (0.06 in.) raised face, ± 0.5 mm (± 0.02 in.)
- (c) 6.4 mm (0.25 in.) raised face, ± 2 mm (± 0.08 in.)
- (d) ring-joint groove tolerances are shown in [Table 29 \(Table 29C\)](#)

7.2 Flange Thickness

(20)

Required tolerances for flange thickness, t_f , are as follows:

Flange Thickness, t_f , mm (in.)	Tolerance, mm (in.)
≤ 25 (≤ 1.0)	+3.0, -0.0 (+0.12, -0.00)
> 25 to ≤ 50 (> 1.0 to ≤ 2.0)	+5.0, -0.0 (+0.20, -0.00)
> 50 to ≤ 75 (> 2.0 to ≤ 3.0)	+8.0, -0.0 (+0.31, -0.00)
> 75 (> 3.0)	+10.0, -0.0 (+0.39, -0.00)

The plus tolerance is applicable to bolting bearing surfaces whether as-forged, as-cast, spot-faced, or back-faced. See [para. 6.3](#).

7.3 Welding End Flange Ends and Hubs

7.3.1 Outside Diameter. The required tolerance for the nominal outside diameter, dimension A of [Figure 1](#), of welding ends of welding neck flanges is +5.0 mm, -2.0 mm (+0.20 in., -0.08 in.). (20)

7.3.2 Inside Diameter. Required tolerances for the nominal inside diameter, dimension B of [Figures 1 and 2](#), of welding ends of welding neck flanges are as follows: (20)

- (a) for Figure 1: +3.0 mm, -2.0 mm (+0.12 in., -0.08 in.)
 (b) for Figure 2: +0.0 mm, -2.0 mm (+0.00 in., -0.08 in.)

7.3.3 Backing Ring Contact Surface. The required tolerance for the bore of the backing ring contact surface of welding neck flanges, dimension *C* of Figure 2, is +0.25 mm, -0.0 mm (+0.01 in., -0.00 in.).

7.3.4 Hub Thickness. Despite the tolerances specified for dimensions *A* and *B*, the thickness of the hub at the welding end shall not be less than 87.5% of the nominal thickness of the pipe having an undertolerance of 12.5% for the pipe wall thickness to which the flange is to be attached or the minimum wall thickness as specified by the purchaser.

(20) **7.4 Hub Length for Welding Neck Flanges**

The required tolerance for the overall length of hubs for welding neck flanges is +3.0 mm, -5.0 mm (+0.12 in., -0.20 in.).

7.5 Drilling and Facing

7.5.1 Bolt Circle Diameter. The required tolerance for all bolt circle diameters is ± 1.5 mm (± 0.06 in.).

7.5.2 Bolt Hole to Bolt Hole. The required tolerance for the center-to-center of adjacent bolt holes is ± 0.8 mm (± 0.03 in.).

7.5.3 Bolt Circle Concentricity. The required tolerance for concentricity between the flange bolt circle diameter and machined facing diameter is 1.5 mm (0.06 in.).

8 PRESSURE TESTING

8.1 Flange Test

Flanges are not required to be pressure tested.

(20)

Figure 1 Welding Ends (Welding Neck Flanges, No Backing Rings)

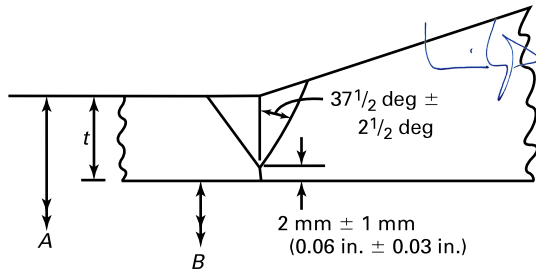

**(a) Bevel for Wall Thickness, t ,
From 5 mm to 22 mm (0.19 in. to 0.88 in.) Inclusive**

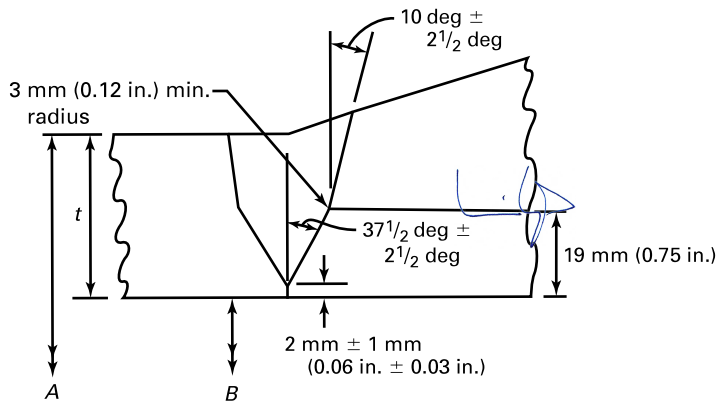

**(b) Bevel for Wall Thickness, t ,
Greater Than 22 mm (0.88 in.)**

Legend:

- A = nominal outside diameter of pipe
- B = nominal inside diameter of pipe
- t = nominal wall thickness of pipe

GENERAL NOTES:

- (a) See [paras. 6.4](#) and [7.4](#) for details and tolerances.
- (b) See [Figure 2](#) for additional details of welding ends.
- (c) When the thickness of the hub at the bevel is greater than that of the pipe to which the flange is joined, the additional thickness may be provided on either the inside or outside, or partially on each side, but the total additional thickness shall not exceed $\frac{1}{2}$ times the nominal wall thickness of the mating pipe (see [Figure 3](#)).

Figure 2 Welding Ends (Welding Neck Flanges With Backing Rings)

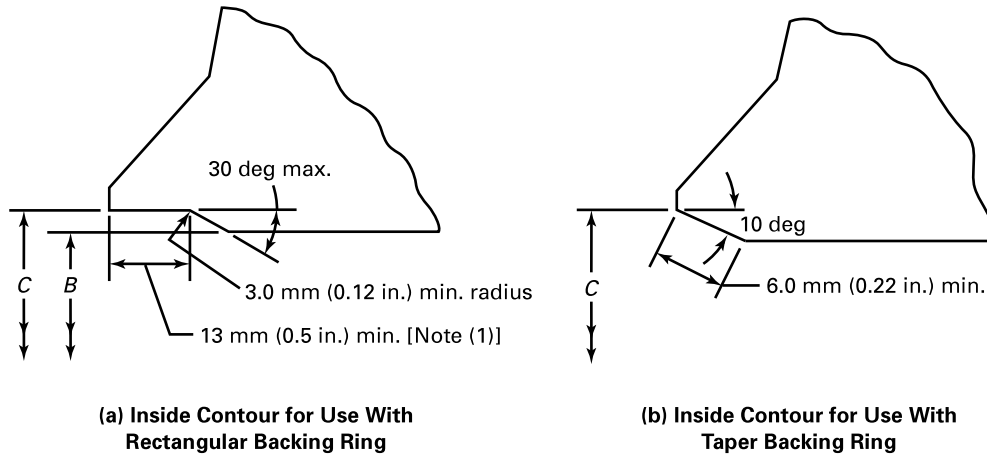

Legend:

- A = nominal outside diameter of welding end
- B = nominal inside diameter of pipe
- $= A - 2t$
- $C = A - 0.79 \text{ mm} - 1.75t - 0.25 \text{ mm}$ for SI units
- $= A - 0.031 \text{ in.} - 1.75t - 0.010 \text{ in.}$ for U.S. customary units

where

- 0.25 mm (0.010 in.) = plus tolerance on diameter C (see para 7.3.3)
- 0.79 mm (0.031 in.) = minus tolerance on O.D. of pipe
- $1.75t = 87\frac{1}{2}\%$ of nominal wall multiplied by 2 to convert into terms of diameter
- t = nominal wall thickness of pipe

GENERAL NOTES:

- (a) See paras. 6.4 and 7.4 for details and tolerances.
- (b) See Figure 1 for welding and details of welding neck flanges.

NOTE: (1) 13 mm (0.5 in.) depth based on the use of a 19 mm (0.75 in) wide backing ring.

(20)

Figure 3 Welding Ends (Welding Neck Flanges)

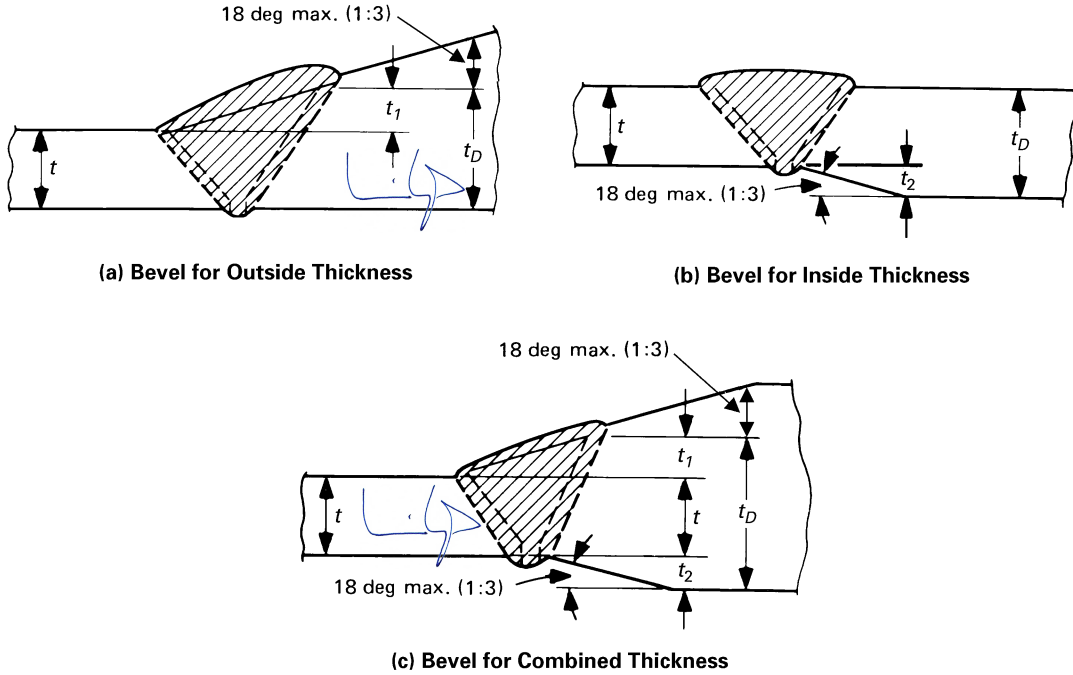

GENERAL NOTES:

- (a) Neither t_1 , t_2 , nor their sum ($t_1 + t_2$) shall exceed $0.5t$.
- (b) When the minimum specified yield strengths of the sections to be joined are unequal, the value of t_D shall at least equal t times the ratio of minimum specified yield strength of the pipe to the minimum specified yield strength of the flange.
- (c) Welding shall be in accordance with the applicable code.
- (d) Additional thickness for welding to higher strength pipe.

Table 1 List of Material Specifications

Material Group No.	Nominal Designation	Applicable ASTM Specifications		
		Forgings	Castings	Plates
Group 1 Materials				
1.1	C-Si	A105	A216 Gr. WCB	A515 Gr. 70
	C-Mn-Si	A350 Gr. LF2	...	A516 Gr. 70
	C-Mn-Si	A537 Cl. 1
	C-Mn-Si-V	A350 Gr. LF6 Cl. 1
	3 $\frac{1}{2}$ Ni	A350 Gr. LF3
1.2	C-Mn-Si	...	A216 Gr. WCC	...
	C-Mn-Si	...	A352 Gr. LCC	...
	C-Mn-Si-V	A350 Gr. LF6 Cl. 2
	2 $\frac{1}{2}$ Ni	...	A352 Gr. LC2	A203 Gr. B
	3 $\frac{1}{2}$ Ni	...	A352 Gr. LC3	A203 Gr. E
1.3	C-Si	...	A352 Gr. LCB	A515 Gr. 65
	C-Mn-Si	A516 Gr. 65
	2 $\frac{1}{2}$ Ni	A203 Gr. A
	3 $\frac{1}{2}$ Ni	A203 Gr. D
	C- $\frac{1}{2}$ Mo	...	A217 Gr. WC1	...
	C- $\frac{1}{2}$ Mo	...	A352 Gr. LC1	...
1.4	C-Si	A515 Gr. 60
	C-Mn-Si	A350 Gr. LF1 Cl. 1	...	A516 Gr. 60
1.5	C- $\frac{1}{2}$ Mo	A182 Gr. F1	...	A204 Gr. A
	C- $\frac{1}{2}$ Mo	A204 Gr. B
1.7	$\frac{1}{2}$ Cr- $\frac{1}{2}$ Mo	A182 Gr. F2
	Ni- $\frac{1}{2}$ Cr- $\frac{1}{2}$ Mo	...	A217 Gr. WC4	...
	$\frac{3}{4}$ Ni- $\frac{3}{4}$ Cr-1Mo	...	A217 Gr. WC5	...
1.9	$\frac{1}{4}$ Cr- $\frac{1}{2}$ Mo	...	A217 Gr. WC6	...
	$\frac{1}{4}$ Cr- $\frac{1}{2}$ Mo-Si	A182 Gr. F11 Cl. 2	...	A387 Gr. 11 Cl. 2
1.10	2 $\frac{1}{4}$ Cr-1Mo	A182 Gr. F22 Cl. 3	A217 Gr. WC9	A387 Gr. 22 Cl. 2
1.11	C- $\frac{1}{2}$ Mo	A240 Gr. C
1.13	5Cr- $\frac{1}{2}$ Mo	A182 Gr. F5A	A217 Gr. C5	...
1.14	9Cr-1Mo	A182 Gr. F9	A217 Gr. C12	...
1.15	9Cr-1Mo-V	A182 Gr. F91 Type 1	A217 Gr. C12A	A387 Gr. 91 Cl. 2
1.17	1Cr- $\frac{1}{2}$ Mo	A182 Gr. F12 Cl. 2
	5Cr- $\frac{1}{2}$ Mo	A182 Gr. F5
1.18	9Cr-2W-V	A182 Gr. F92
Group 2 Materials				
2.1	18Cr-8Ni	A182 Gr. F304	A351 Gr. CF3	A240 Gr. 304
	18Cr-8Ni	A182 Gr. F304H	A351 Gr. CF8	A240 Gr. 304H
2.2	16Cr-12Ni-2Mo	A182 Gr. F316	A351 Gr. CF3M	A240 Gr. 316
	16Cr-12Ni-2Mo	A182 Gr. F316H	A351 Gr. CF8M	A240 Gr. 316H
	18Cr-13Ni-3Mo	A182 Gr. F317	...	A240 Gr. 317
	19Cr-10Ni-3Mo	...	A351 Gr. CG8M	...
2.3	18Cr-8Ni	A182 Gr. F304L	...	A240 Gr. 304L
	16Cr-12Ni-2Mo	A182 Gr. F316L	...	A240 Gr. 316L
	18Cr-13Ni-3Mo	A182 Gr. F317L
2.4	18Cr-10Ni-Ti	A182 Gr. F321	...	A240 Gr. 321
	18Cr-10Ni-Ti	A182 Gr. F321H	...	A240 Gr. 321H

Table 1 List of Material Specifications (Cont'd)

Material Group No.	Nominal Designation	Applicable ASTM Specifications		
		Forgings	Castings	Plates
Group 2 Materials (Cont'd)				
2.5	18Cr-10Ni-Cb	A182 Gr. F347	...	A240 Gr. 347
	18Cr-10Ni-Cb	A182 Gr. F347H	...	A240 Gr. 347H
	18Cr-10Ni-Cb	A182 Gr. F348	...	A240 Gr. 348
	18Cr-10Ni-Cb	A182 Gr. F348H	...	A240 Gr. 348H
2.6	23Cr-12Ni	A240 Gr. 309H
2.7	25Cr-20Ni	A182 Gr. F310	...	A240 Gr. 310H
2.8	20Cr-18Ni-6Mo	A182 Gr. F44	A351 Gr. CK3MCuN	A240 Gr. S31254
	22Cr-5Ni-3Mo-N	A182 Gr. F51	...	A240 Gr. S31803
	25Cr-7Ni-4Mo-N	A182 Gr. F53	...	A240 Gr. S32750
	24Cr-10Ni-4Mo-V	...	A351 Gr. CE8MN	...
	25Cr-5Ni-2Mo-3Cu	...	A995 Gr. CD4MCu	...
	25Cr-7Ni-3.5Mo-W-Cb	...	A995 Gr. CD3MWCuN	...
	25Cr-7Ni-3.5Mo-N-Cu-W	A182 Gr. F55	...	A240 Gr. S32760
2.9	23Cr-12Ni	A240 Gr. 309S
	25Cr-20Ni	A240 Gr. 310S
2.10	25Cr-12Ni	...	A351 Gr. CH8	...
	25Cr-12Ni	...	A351 Gr. CH20	...
2.11	18Cr-10Ni-Cb	...	A351 Gr. CF8C	...
2.12	25Cr-20Ni	...	A351 Gr. CK20	...

Table 2 List of Bolting Specifications (Applicable ASTM Specifications)

Bolting Materials					
High Strength [Note (1)]		Intermediate Strength [Note (2)]		Low Strength [Note (3)]	
Spec.-Grade	Notes	Spec.-Grade	Notes	Spec.-Grade	Notes
A193-B7	...	A193-B5	...	A193-B8 Cl. 1	(4)
A193-B16	...	A193-B6	...	A193-B8C Cl. 1	(4)
		A193-B6X	...	A193-B8M Cl. 1	(4)
A320-L7	(5)	A193-B7M	...	A193-B8T Cl. 1	(4)
A320-L7A	(5)				
A320-L7B	(5)	A193-B8 Cl. 2, 2B	(6)	A193-B8A	(4)
A320-L7C	(5)	A193-B8C Cl. 2	(6)	A193-B8CA	...
A320-L43	(5)	A193-B8M Cl. 2, 2B, 2C	(6)	A193-B8MA	...
		A193-B8T Cl. 2	(6)	A193-B8TA	(4)
A354-BC	...				
A354-BD	...	A320-B8 Cl. 2	(6)	A307-B	(7)
		A320-B8C Cl. 2	(6)		
A540-B21	...	A320-B8F Cl. 2	(6)	A320-B8 Cl. 1	(4)
A540-B22	...	A320-B8M Cl. 2	(6)	A320-B8C Cl. 1	(4)
A540-B23	...	A320-B8T Cl. 2	(6)	A320-B8M Cl. 1	(4)
A540-B24	...			A320-B8T Cl. 1	(4)
		A449	(8)		
		A453-651	(9)		
		A453-660	(9)		

GENERAL NOTES:

- (a) Bolting material shall not be used beyond temperature limits specified in the governing code.
- (b) ASME Boiler and Pressure Vessel Code, Section II materials, which also meet the requirements of the listed ASTM specifications, may also be used.
- (c) Repair welding of bolting material is prohibited.

NOTES:

- (1) These bolting materials may be used with all listed materials and gaskets. See [para. 5.3.2](#).
- (2) These bolting materials may be used with all listed materials and gaskets, provided it has been verified that a sealed joint can be maintained under rated working pressure and temperature. See [para. 5.3.3](#).
- (3) These bolting materials may be used with all listed materials but are limited to Classes 75, 150, and 300 joints (see [para. 5.3.4](#)). See [para. 5.4](#) for recommended gasket practices.
- (4) This austenitic stainless material has been carbide solution treated but not strain hardened. Use A194 nuts of corresponding material.
- (5) This ferritic material is intended for low temperature service. Use A194 Gr. 4 or Gr. 7 nuts.
- (6) This austenitic stainless material has been carbide solution treated and strain hardened. Use A194 nuts of corresponding material.
- (7) This carbon steel fastener shall not be used above 200°C (400°F) or below -29°C (-20°F). See also Note (3). Bolts with drilled or undersized heads shall not be used.
- (8) Acceptable nuts for use with quenched and tempered bolts are A194 Gr. 2 and Gr. 2H. Mechanical property requirements for studs shall be the same as those for bolts.
- (9) This special alloy is intended for high temperature service with austenitic stainless steel.

Table 3 Pressure–Temperature Ratings for Group 1.1 Materials

Nominal Designation	Forgings		Castings		Plates	
C–Si	A105 [Note (1)]		A216 Gr. WCB [Note (1)]		A515 Gr. 70 [Note (1)]	
C–Mn–Si	A350 Gr. LF2 [Note (1)]		...		A516 Gr. 70 [Notes (1), (2)]	
C–Mn–Si		A537 Cl. 1 [Note (3)]	
C–Mn–Si–V	A350 Gr. LF6 Cl. 1 [Note (4)]		
3½Ni	A350 Gr. LF3		
Working Pressure by Classes, bar						
Temperature, °C	75	150	300	400	600	900
–29 to 38	9.8	19.6	51.1	68.1	102.1	153.2
50	9.6	19.2	50.1	66.8	100.2	150.4
100	8.8	17.7	46.6	62.1	93.2	139.8
150	7.9	15.8	45.1	60.1	90.2	135.2
200	6.9	13.8	43.8	58.4	87.6	131.4
250	6.0	12.1	41.9	55.9	83.9	125.8
300	5.1	10.2	39.8	53.1	79.6	119.5
325	4.6	9.3	38.7	51.6	77.4	116.1
350	3.1	8.4	37.6	50.1	75.1	112.7
375	...	7.4	36.4	48.5	72.7	109.1
400	...	6.5	34.7	46.3	69.4	104.2
425	...	5.5	28.8	38.4	57.5	86.3
450	...	4.6	23.0	30.7	46.0	69.0
475	...	3.7	17.4	23.2	34.9	52.3
500	...	2.8	11.8	15.7	23.5	35.3
538	...	1.4	5.9	7.9	11.8	17.7

NOTES:

- (1) Upon prolonged exposure to temperatures above 425°C, the carbide phase of steel may be converted to graphite. Permissible, but not recommended for prolonged use above 425°C.
- (2) Not to be used over 455°C.
- (3) Not to be used over 370°C.
- (4) Not to be used over 260°C.

Table 3C Pressure-Temperature Ratings for Group 1.1 Materials

Nominal Designation	Forgings		Castings		Plates	
C-Si	A105 [Note (1)]		A216 Gr. WCB [Note (1)]		A515 Gr. 70 [Note (1)]	
C-Mn-Si	A350 Gr. LF2 [Note (1)]		...		A516 Gr. 70 [Notes (1), (2)]	
C-Mn-Si			A537 Cl. 1 [Note (3)]	
C-Mn-Si-V	A350 Gr. LF6 Cl. 1 [Note (4)]		
3½Ni	A350 Gr. LF3		
Working Pressure by Classes, psig						
Temperature, °F	75	150	300	400	600	900
-20 to 100	140	285	740	985	1,480	2,220
200	130	260	680	905	1,360	2,035
300	115	230	655	870	1,310	1,965
400	100	200	635	845	1,265	1,900
500	85	170	605	805	1,205	1,810
600	70	140	570	755	1,135	1,705
650	60	125	550	730	1,100	1,650
700	...	110	530	710	1,060	1,590
750	...	95	505	675	1,015	1,520
800	...	80	410	550	825	1,235
850	...	65	320	425	640	955
900	...	50	230	305	460	690
950	...	35	135	185	275	410
1,000	...	20	85	115	170	255

NOTES:

- (1) Upon prolonged exposure to temperatures above 800°F, the carbide phase of steel may be converted to graphite. Permissible, but not recommended for prolonged use above 800°F.
- (2) Not to be used over 850°F.
- (3) Not to be used over 700°F.
- (4) Not to be used over 500°F.

Table 4 Pressure–Temperature Ratings for Group 1.2 Materials

Nominal Designation	Forgings		Castings		Plates	
C–Mn–Si	...		A216 Gr. WCC [Note (1)]			...
C–Mn–Si	...		A352 Gr. LCC [Note (2)]			...
C–Mn–Si–V	A350 Gr. LF6 Cl. 2 [Note (3)]	
2½Ni	...		A352 Gr. LC2		A203 Gr. B [Note (1)]	
3½Ni	...		A352 Gr. LC3 [Note (2)]		A203 Gr. E [Note (1)]	
Working Pressure by Classes, bar						
Temperature, °C	75	150	300	400	600	900
–29 to 38	9.9	19.8	51.7	68.9	103.4	155.1
50	9.8	19.5	51.7	68.9	103.4	155.1
100	8.8	17.7	51.5	68.7	103.0	154.6
150	7.9	15.8	50.2	66.8	100.3	150.5
200	6.9	13.8	48.6	64.8	97.2	145.8
250	6.0	12.1	46.3	61.7	92.7	139.0
300	5.1	10.2	42.9	57.0	85.7	128.6
325	4.6	9.3	41.4	55.0	82.6	124.0
350	3.1	8.4	40.0	53.4	80.0	120.1
375	...	7.4	37.8	50.4	75.7	113.5
400	...	6.5	34.7	46.3	69.4	104.2
425	...	5.5	28.8	38.4	57.5	86.3
450	...	4.6	23.0	30.7	46.0	69.0
475	...	3.7	17.1	22.8	34.2	51.3
500	...	2.8	11.6	15.4	23.2	34.7
538	...	1.4	5.9	7.9	11.8	17.7

NOTES:

- (1) Upon prolonged exposure to temperatures above 425°C, the carbide phase of steel may be converted to graphite. Permissible, but not recommended for prolonged use above 425°C.
- (2) Not to be used over 340°C.
- (3) Not to be used over 260°C.

Table 4C Pressure-Temperature Ratings for Group 1.2 Materials

Nominal Designation	Forgings		Castings		Plates	
C-Mn-Si	...		A216 Gr. WCC [Note (1)]			...
C-Mn-Si	...		A352 Gr. LCC [Note (2)]			...
C-Mn-Si-V	A350 Gr. LF6 Cl. 2 [Note (3)]	
2½Ni	...		A352 Gr. LC2		A203 Gr. B [Note (1)]	
3½Ni	...		A352 Gr. LC3 [Note (2)]		A203 Gr. E [Note (1)]	
Working Pressure by Classes, psig						
Temperature, °F	75	150	300	400	600	900
-20 to 100	145	290	750	1,000	1,500	2,250
200	130	260	750	1,000	1,500	2,250
300	115	230	730	970	1,455	2,185
400	100	200	705	940	1,405	2,110
500	85	170	665	885	1,330	1,995
600	70	140	605	805	1,210	1,815
650	60	125	590	785	1,175	1,765
700	...	110	555	740	1,110	1,665
750	...	95	505	675	1,015	1,520
800	...	80	410	550	825	1,235
850	...	65	320	425	640	955
900	...	50	225	295	445	670
950	...	35	135	185	275	410
1,000	...	20	85	115	170	255

NOTES:

- (1) Upon prolonged exposure to temperatures above 800°F, the carbide phase of steel may be converted to graphite. Permissible, but not recommended for prolonged use above 800°F.
- (2) Not to be used over 650°F.
- (3) Not to be used over 500°F.

Table 5 Pressure–Temperature Ratings for Group 1.3 Materials

Nominal Designation	Forgings	Castings	Plates			
C–Si	...	A352 Gr. LCB [Note (1)]	A515 Gr. 65 [Note (2)]			
C–Mn–Si	A516 Gr. 65 [Notes (2), (3)]			
C– $\frac{1}{2}$ Mo	...	A217 Gr. WC1 [Notes (4)–(6)]	...			
C– $\frac{1}{2}$ Mo	...	A352 Gr. LC1 [Note (1)]	...			
2 $\frac{1}{2}$ Ni	A203 Gr. A [Note (2)]			
3 $\frac{1}{2}$ Ni	A203 Gr. D [Note (2)]			
Working Pressure by Classes, bar						
Temperature, °C	75	150	300	400	600	900
–29 to 38	9.2	18.4	48.0	64.0	96.0	144.1
50	9.1	18.2	47.5	63.3	94.9	142.4
100	8.7	17.4	45.3	60.5	90.7	136.0
150	7.9	15.8	43.9	58.6	87.9	131.8
200	6.9	13.8	42.5	56.7	85.1	127.6
250	6.0	12.1	40.8	54.4	81.6	122.3
300	5.1	10.2	38.7	51.6	77.4	116.1
325	4.6	9.3	37.6	50.1	75.2	112.7
350	3.1	8.4	36.4	48.5	72.8	109.2
375	...	7.4	35.0	46.6	69.9	104.9
400	...	6.5	32.6	43.5	65.2	97.9
425	...	5.5	27.3	36.4	54.6	81.9
450	...	4.6	21.6	28.8	43.2	64.8
475	...	3.7	15.7	20.9	31.3	47.0
500	...	2.8	11.1	14.8	22.1	33.2
538	...	1.4	5.9	7.9	11.8	17.7

NOTES:

- (1) Not to be used over 340°C.
- (2) Upon prolonged exposure to temperatures above 425°C, the carbide phase of steel may be converted to graphite. Permissible, but not recommended for prolonged use above 425°C.
- (3) Not to be used over 455°C.
- (4) Upon prolonged exposure to temperatures above 465°C, the carbide phase of steel may be converted to graphite. Permissible, but not recommended for prolonged use above 465°C.
- (5) Use normalized and tempered material only.
- (6) The deliberate addition of any element not listed in ASTM A217, Table 1 is prohibited, except that calcium (Ca) and manganese (Mn) may be added for deoxidation.

Table 5C Pressure–Temperature Ratings for Group 1.3 Materials

Nominal Designation	Forgings		Castings		Plates	
C–Si	...	A352 Gr. LCB [Note (1)]			A515 Gr. 65 [Note (2)]	
C–Mn–Si		A516 Gr. 65 [Notes (2), (3)]	
C– $\frac{1}{2}$ Mo	...	A217 Gr. WC1 [Notes (4)–(6)]			...	
C– $\frac{1}{2}$ Mo	...	A352 Gr. LC1 [Note (1)]			...	
2 $\frac{1}{2}$ Ni		A203 Gr. A [Note (2)]	
3 $\frac{1}{2}$ Ni		A203 Gr. D [Note (2)]	
Working Pressure by Classes, psig						
Temperature, °F	75	150	300	400	600	900
–20 to 100	135	265	695	930	1,395	2,090
200	125	255	660	880	1,320	1,980
300	115	230	640	850	1,275	1,915
400	100	200	615	820	1,230	1,845
500	85	170	585	780	1,175	1,760
600	70	140	550	735	1,105	1,655
650	60	125	535	710	1,065	1,600
700	...	110	510	685	1,025	1,535
750	...	95	475	635	955	1,430
800	...	80	390	520	780	1,175
850	...	65	300	400	595	895
900	...	50	200	270	405	605
950	...	35	135	185	275	410
1,000	...	20	85	115	170	255

NOTES:

- (1) Not to be used over 650°F.
- (2) Upon prolonged exposure to temperatures above 800°F, the carbide phase of steel may be converted to graphite. Permissible, but not recommended for prolonged use above 800°F.
- (3) Not to be used over 850°F.
- (4) Upon prolonged exposure to temperatures above 875°F, the carbide phase of steel may be converted to graphite. Permissible, but not recommended for prolonged use above 875°F.
- (5) Use normalized and tempered material only.
- (6) The deliberate addition of any element not listed in ASTM A217, Table 1 is prohibited, except that calcium (Ca) and manganese (Mn) may be added for deoxidation.

Table 6 Pressure–Temperature Ratings for Group 1.4 Materials

Nominal Designation	Forgings		Castings		Plates	
C–Si		A515 Gr. 60 [Note (1)]	
C–Mn–Si	A350 Gr. LF1 Cl. 1 [Note (1)]		...		A516 Gr. 60 [Notes (1), (2)]	
	Working Pressure by Classes, bar					
Temperature, °C	75	150	300	400	600	900
–29 to 38	8.2	16.3	42.6	56.7	85.1	127.7
50	8.0	16.0	41.8	55.7	83.5	125.3
100	7.4	14.9	38.8	51.8	77.7	116.5
150	7.2	14.4	37.6	50.1	75.1	112.7
200	6.9	13.8	36.4	48.5	72.8	109.2
250	6.0	12.1	34.9	46.6	69.8	104.7
300	5.1	10.2	33.2	44.2	66.4	99.5
325	4.6	9.3	32.2	43.0	64.5	96.7
350	3.1	8.4	31.2	41.7	62.5	93.7
375	...	7.4	30.4	40.5	60.7	91.1
400	...	6.5	29.3	39.1	58.7	88.0
425	...	5.5	25.8	34.4	51.5	77.3
450	...	4.6	21.4	28.5	42.7	64.1
475	...	3.7	14.1	18.8	28.2	42.3
500	...	2.8	10.3	13.7	20.6	30.9
538	...	1.4	5.9	7.9	11.8	17.7

NOTES:

(1) Upon prolonged exposure to temperatures above 425°C, the carbide phase of steel may be converted to graphite. Permissible, but not recommended for prolonged use above 425°C.

(2) Not to be used over 455°C.

Table 6C Pressure–Temperature Ratings for Group 1.4 Materials

Nominal Designation	Forgings		Castings		Plates	
C–Si		A515 Gr. 60 [Note (1)]	
C–Mn–Si	A350 Gr. LF1 Cl. 1 [Note(1)]		...		A516 Gr. 60 [Notes (1), (2)]	
Working Pressure by Classes, psig						
Temperature, °F	75	150	300	400	600	900
–20 to 100	120	235	615	825	1,235	1,850
200	110	215	565	755	1,130	1,695
300	105	210	545	725	1,090	1,635
400	100	200	525	700	1,055	1,580
500	85	170	500	670	1,005	1,505
600	70	140	475	630	945	1,420
650	60	125	455	610	915	1,370
700	...	110	440	590	885	1,325
750	...	95	430	570	855	1,285
800	...	80	370	495	740	1,110
850	...	65	300	400	595	895
900	...	50	170	230	345	515
950	...	35	135	185	275	410
1,000	...	20	85	115	170	255

NOTES:

- (1) Upon prolonged exposure to temperature above 800°F, the carbide phase of steel may be converted to graphite. Permissible, but not recommended for prolonged use above 800°F.
- (2) Not to be used over 850°F.

Table 7 Pressure–Temperature Ratings for Group 1.5 Materials

Nominal Designation	Forgings		Castings		Plates	
C- $\frac{1}{2}$ Mo	A182 Gr. F1 [Note (1)]		...		A204 Gr. A [Note (1)]	
C- $\frac{1}{2}$ Mo		A204 Gr. B [Note (1)]	
Working Pressure by Classes, bar						
Temperature, °C	75	150	300	400	600	900
-29 to 38	9.2	18.4	48.0	64.0	96.0	144.1
50	9.2	18.4	48.0	64.0	96.0	144.1
100	8.8	17.7	47.9	63.9	95.9	143.8
150	7.9	15.8	47.3	63.1	94.7	142.0
200	6.9	13.8	45.8	61.1	91.6	137.4
250	6.0	12.1	44.5	59.3	89.0	133.5
300	5.1	10.2	42.9	57.0	85.7	128.6
325	4.6	9.3	41.4	55.0	82.6	124.0
350	3.1	8.4	40.3	53.6	80.4	120.7
375	...	7.4	38.9	51.6	77.6	116.5
400	...	6.5	36.5	48.9	73.3	109.8
425	...	5.5	35.2	46.5	70.0	105.1
450	...	4.6	33.7	45.1	67.7	101.4
475	...	3.7	31.7	42.3	63.4	95.1
500	...	2.8	24.1	32.1	48.1	72.2
538	...	1.4	11.3	15.1	22.7	34.0

NOTE: (1) Upon prolonged exposure to temperatures above 465°C, the carbide phase of carbon-molybdenum steel may be converted to graphite. Permissible, but not recommended for prolonged use above 465°C.

Table 7C Pressure–Temperature Ratings for Group 1.5 Materials

Nominal Designation	Forgings		Castings		Plates	
C-½Mo	A182 Gr. F1 [Note (1)]		...		A204 Gr. A [Note (1)]	
C-½Mo		A204 Gr. B [Note (1)]	
Working Pressure by Classes, psig						
Temperature, °F	75	150	300	400	600	900
-20 to 100	135	265	695	930	1,395	2,090
200	130	260	695	930	1,395	2,090
300	115	230	685	915	1,375	2,060
400	100	200	660	885	1,325	1,985
500	85	170	640	855	1,285	1,925
600	70	140	605	805	1,210	1,815
650	60	125	590	785	1,175	1,765
700	...	110	570	755	1,135	1,705
750	...	95	530	710	1,065	1,595
800	...	80	510	675	1,015	1,525
850	...	65	485	650	975	1,460
900	...	50	450	600	900	1,350
950	...	35	280	375	560	845
1,000	...	20	165	220	330	495

NOTE: (1) Upon prolonged exposure to temperatures above 875°F, the carbide phase of carbon-molybdenum steel may be converted to graphite. Permissible, but not recommended for prolonged use above 875°F.

Table 8 Pressure–Temperature Ratings for Group 1.7 Materials

Nominal Designation	Forgings		Castings			Plates
$\frac{1}{2}\text{Cr}-\frac{1}{2}\text{Mo}$	A182 Gr. F2 [Note (1)]		
$\text{Ni}-\frac{1}{2}\text{Cr}-\frac{1}{2}\text{Mo}$...			A217 Gr. WC4 [Notes (1)–(3)]		...
$\frac{3}{4}\text{Ni}-\frac{3}{4}\text{Cr}-1\text{Mo}$...			A217 Gr. WC5 [Notes (2), (3)]		...
Working Pressure by Classes, bar						
Temperature, °C	75	150	300	400	600	900
–29 to 38	9.9	19.8	51.7	68.9	103.4	155.1
50	9.8	19.5	51.7	68.9	103.4	155.1
100	8.8	17.7	51.5	68.7	103.0	154.6
150	7.9	15.8	50.3	66.8	100.3	150.6
200	6.9	13.8	48.6	64.8	97.2	145.8
250	6.0	12.1	46.3	61.7	92.7	139.0
300	5.1	10.2	42.9	57.0	85.7	128.6
325	4.6	9.3	41.4	55.0	82.6	124.0
350	3.1	8.4	40.3	53.6	80.4	120.7
375	...	7.4	38.9	51.6	77.6	116.5
400	...	6.5	36.5	48.9	73.3	109.8
425	...	5.5	35.2	46.5	70.0	105.1
450	...	4.6	33.7	45.1	67.7	101.4
475	...	3.7	31.7	42.3	63.4	95.1
500	...	2.8	26.7	35.6	53.4	80.1
538	...	1.4	13.9	18.6	27.9	41.8
550	12.6	16.8	25.2	37.8
575	7.2	9.6	14.4	21.5

NOTES:

- (1) Not to be used over 538°C.
- (2) Use normalized and tempered material only.
- (3) The deliberate addition of any element not listed in ASTM A217, Table 1 is prohibited, except that calcium (Ca) and manganese (Mn) may be added for deoxidation.

Table 8C Pressure-Temperature Ratings for Group 1.7 Materials

Nominal Designation	Forgings		Castings			Plates
$\frac{1}{2}$ Cr- $\frac{1}{2}$ Mo	A182 Gr. F2 [Note (1)]	
Ni- $\frac{1}{2}$ Cr- $\frac{1}{2}$ Mo	...		A217 Gr. WC4 [Notes (1)-(3)]			...
$\frac{3}{4}$ Ni- $\frac{3}{4}$ Cr-1Mo	...		A217 Gr. WC5 [Notes (2), (3)]			...
Working Pressure by Classes, psig						
Temperature, °F	75	150	300	400	600	900
-20 to 100	145	290	750	1,000	1,500	2,250
200	130	260	750	1,000	1,500	2,250
300	115	230	730	970	1,455	2,185
400	100	200	705	940	1,410	2,115
500	85	170	665	885	1,330	1,995
600	70	140	605	805	1,210	1,815
650	60	125	590	785	1,175	1,765
700	...	110	570	755	1,135	1,705
750	...	95	530	710	1,065	1,595
800	...	80	510	675	1,015	1,525
850	...	65	485	650	975	1,460
900	...	50	450	600	900	1,350
950	...	35	315	420	630	945
1,000	...	20	200	270	405	605
1,050	160	210	315	475

NOTES:

- (1) Not to be used over 1,000°F.
- (2) Use normalized and tempered material only.
- (3) The deliberate addition of any element not listed in ASTM A217, Table 1 is prohibited, except that calcium (Ca) and manganese (Mn) may be added for deoxidation.

Table 9 Pressure–Temperature Ratings for Group 1.9 Materials

Nominal Designation	Forgings		Castings		Plates	
	Working Pressure by Classes, bar					
Temperature, °C	75	150	300	400	600	900
1¼Cr–½Mo	A217 Gr. WC6 [Notes (1), (2), (3)]
1¼Cr–½Mo–Si	A182 Gr. F11 Cl. 2 [Notes (1), (4)]	A387 Gr. 11 Cl. 2 [Note (4)]	...
-29 to 38	9.9	19.8	51.7	68.9	103.4	155.1
50	9.8	19.5	51.7	68.9	103.4	155.1
100	8.8	17.7	51.5	68.6	103.0	154.4
150	7.9	15.8	49.7	66.3	99.5	149.2
200	6.9	13.8	48.0	63.9	95.9	143.9
250	6.0	12.1	46.3	61.7	92.7	139.0
300	5.1	10.2	42.9	57.0	85.7	128.6
325	4.6	9.3	41.4	55.0	82.6	124.0
350	3.1	8.4	40.3	53.6	80.4	120.7
375	...	7.4	38.9	51.6	77.6	116.5
400	...	6.5	36.5	48.9	73.3	109.8
425	...	5.5	35.2	46.5	70.0	105.1
450	...	4.6	33.7	45.1	67.7	101.4
475	...	3.7	31.7	42.3	63.4	95.1
500	...	2.8	25.7	34.3	51.5	77.2
538	...	1.4	14.9	19.9	29.8	44.7
550	12.7	16.9	25.4	38.1
575	8.8	11.7	17.6	26.4
600	6.1	8.1	12.2	18.3
625	4.3	5.7	8.5	12.8
650	2.8	3.8	5.7	8.5

NOTES:

(1) Use normalized and tempered material only.

(2) Not to be used over 590°C.

(3) The deliberate addition of any element not listed in ASTM A217, Table 1 is prohibited, except that calcium (Ca) and manganese (Mn) may be added for deoxidation.

(4) Permissible, but not recommended for prolonged use above 590°C.

Table 9C Pressure–Temperature Ratings for Group 1.9 Materials

Nominal Designation	Forgings		Castings		Plates	
	Working Pressure by Classes, psig					
Temperature, °F	75	150	300	400	600	900
1¼Cr–½Mo	A217 Gr. WC6 [Notes (1), (2), (3)]	
1¼Cr–½Mo–Si	A182 Gr. F11 Cl. 2 [Notes (1), (4)]		A387 Gr. 11 Cl. 2 [Note (4)]	
-20 to 100	145	290	750	1,000	1,500	2,250
200	130	260	750	1,000	1,500	2,250
300	115	230	720	965	1,445	2,165
400	100	200	695	925	1,385	2,080
500	85	170	665	885	1,330	1,995
600	70	140	605	805	1,210	1,815
650	60	125	590	785	1,175	1,765
700	...	110	570	755	1,135	1,705
750	...	95	530	710	1,065	1,595
800	...	80	510	675	1,015	1,525
850	...	65	485	650	975	1,460
900	...	50	450	600	900	1,350
950	...	35	320	425	640	955
1,000	...	20	215	290	430	650
1,050	145	190	290	430
1,100	95	130	190	290
1,150	65	85	130	195
1,200	40	55	80	125

NOTES:

- (1) Use normalized and tempered material only.
- (2) Not to be used over 1,100°F.
- (3) The deliberate addition of any element not listed in ASTM A217, Table 1 is prohibited, except that calcium (Ca) and manganese (Mn) may be added for deoxidation.
- (4) Permissible, but not recommended for prolonged use above 1,100°F.

Table 10 Pressure–Temperature Ratings for Group 1.10 Materials

Nominal Designation	Forgings		Castings		Plates	
	Working Pressure by Classes, bar					
Temperature, °C	75	150	300	400	600	900
2½Cr-1Mo	A182 Gr. F22 Cl. 3 [Note (1)]		A217 Gr. WC9 [Notes (2)–(4)]		A387 Gr. 22 Cl. 2 [Note (1)]	
-29 to 38	9.9	19.8	51.7	68.9	103.4	155.1
50	9.8	19.5	51.7	68.9	103.4	155.1
100	8.8	17.7	51.5	68.7	103.0	154.6
150	7.9	15.8	50.3	66.8	100.3	150.6
200	6.9	13.8	48.6	64.8	97.2	145.8
250	6.0	12.1	46.3	61.7	92.7	139.0
300	5.1	10.2	42.9	57.0	85.7	128.6
325	4.6	9.3	41.4	55.0	82.6	124.0
350	3.1	8.4	40.3	53.6	80.4	120.7
375	0.0	7.4	38.9	51.6	77.6	116.5
400	...	6.5	36.5	48.9	73.3	109.8
425	...	5.5	35.2	46.5	70.0	105.1
450	...	4.6	33.7	45.1	67.7	101.4
475	...	3.7	31.7	42.3	63.4	95.1
500	...	2.8	28.2	37.6	56.5	84.7
538	...	1.4	18.4	24.6	36.9	55.3
550	15.6	20.8	31.3	46.9
575	10.5	14.0	21.1	31.6
600	6.9	9.2	13.8	20.7
625	4.5	6.0	8.9	13.4
650	2.8	3.8	5.7	8.5

NOTES:

- (1) Permissible, but not recommended for prolonged use above 590°C.
- (2) Use normalized and tempered material only.
- (3) Not to be used over 590°C.
- (4) The deliberate addition of any element not listed in ASTM A217, Table 1 is prohibited, except that calcium (Ca) and manganese (Mn) may be added for deoxidation.

Table 10C Pressure–Temperature Ratings for Group 1.10 Materials

Nominal Designation	Forgings		Castings		Plates	
	Working Pressure by Classes, psig					
Temperature, °F	75	150	300	400	600	900
2½Cr–1Mo	A182 Gr. F22 Cl. 3 [Note (1)]		A217 Gr. WC9 [Notes (2)–(4)]		A387 Gr. 22 Cl. 2 [Note (1)]	
–20 to 100	145	290	750	1,000	1,500	2,250
200	130	260	750	1,000	1,500	2,250
300	115	230	730	970	1,455	2,185
400	100	200	705	940	1,410	2,115
500	85	170	665	885	1,330	1,995
600	70	140	605	805	1,210	1,815
650	60	125	590	785	1,175	1,765
700	...	110	570	755	1,135	1,705
750	...	95	530	710	1,065	1,595
800	...	80	510	675	1,015	1,525
850	...	65	485	650	975	1,460
900	...	50	450	600	900	1,350
950	...	35	385	515	755	1,160
1,000	...	20	265	355	535	800
1,050	175	235	350	525
1,100	110	145	220	330
1,150	70	90	135	205
1,200	40	55	80	125

NOTES:

- (1) Permissible, but not recommended for prolonged use above 1,100°F.
- (2) Use normalized and tempered material only.
- (3) Not to be used over 1,100°F.
- (4) The deliberate addition of any element not listed in ASTM A217, Table 1 is prohibited, except that calcium (Ca) and manganese (Mn) may be added for deoxidation.

Table 11 Pressure–Temperature Ratings for Group 1.11 Materials

Nominal Designation	Forgings		Castings		Plates	
	C- $\frac{1}{2}$ Mo					
Temperature, °C	Working Pressure by Classes, bar					
	75	150	300	400	600	900
-29 to 38	10.0	20.0	51.7	68.9	103.4	155.1
50	9.8	19.5	51.7	68.9	103.4	155.1
100	8.8	17.7	51.5	68.7	103.0	154.6
150	7.9	15.8	50.3	66.8	100.3	150.6
200	6.9	13.8	48.6	64.8	97.2	145.8
250	6.0	12.1	46.3	61.7	92.7	139.0
300	5.1	10.2	42.9	57.0	85.7	128.6
325	4.6	9.3	41.4	55.0	82.6	124.0
350	3.1	8.4	40.3	53.6	80.4	120.7
375	0.0	7.4	38.9	51.6	77.6	116.5
400	...	6.5	36.5	48.9	73.3	109.8
425	...	5.5	35.2	46.5	70.0	105.1
450	...	4.6	33.7	45.1	67.7	101.4
475	...	3.7	31.7	42.3	63.4	95.1
500	...	2.8	23.6	31.4	47.1	70.7
538	...	1.4	11.3	15.1	22.7	34.0
550	11.3	15.1	22.7	34.0
575	10.1	13.4	20.1	30.2
600	7.1	9.5	14.2	21.3
625	5.3	7.1	10.6	15.9
650	3.1	4.1	6.1	9.2

NOTE: (1) Upon prolonged exposure to temperatures above 465°C, the carbide phase of carbon-molybdenum steel may be converted to graphite. Permissible, but not recommended for prolonged use above 465°C.

Table 11C Pressure–Temperature Ratings for Group 1.11 Materials

Nominal Designation	Forgings		Castings		Plates	
	Working Pressure by Classes, psig					
Temperature, °F	75	150	300	400	600	900
C- ¹ / ₂ Mo	A204 Gr. C [Note (1)]	
-20 to 100	145	290	750	1,000	1,500	2,250
200	130	260	750	1,000	1,500	2,250
300	115	230	730	970	1,455	2,185
400	100	200	705	940	1,410	2,115
500	85	170	665	885	1,330	1,995
600	70	140	605	805	1,210	1,815
650	60	125	590	785	1,175	1,765
700	...	110	570	755	1,135	1,705
750	...	95	530	710	1,065	1,595
800	...	80	510	675	1,015	1,525
850	...	65	485	650	975	1,460
900	...	50	450	600	900	1,345
950	...	35	280	375	560	845
1,000	...	20	165	220	330	495
1,050	165	220	330	495
1,100	110	145	220	330
1,150	80	110	165	245
1,200	45	60	90	135

NOTE: (1) Upon prolonged exposure to temperatures above 875°F, the carbide phase of carbon-molybdenum steel may be converted to graphite. Permissible, but not recommended for prolonged use above 875°F.

Table 12 Pressure–Temperature Ratings for Group 1.13 Materials

Nominal Designation	Forgings		Castings			Plates
	A182 Gr. F5a		A217 Gr. C5 [Notes (1), (2)]			
5Cr- $\frac{1}{2}$ Mo	...					
	Working Pressure by Classes, bar					
Temperature, °C	75	150	300	400	600	900
-29 to 38	10.0	20.0	51.7	68.9	103.4	155.1
50	9.8	19.5	51.7	68.9	103.4	155.1
100	8.8	17.7	51.5	68.7	103.0	154.6
150	7.9	15.8	50.3	66.8	100.3	150.6
200	6.9	13.8	48.6	64.8	97.2	145.8
250	6.0	12.1	46.3	61.7	92.7	139.0
300	5.1	10.2	42.9	57.0	85.7	128.6
325	4.6	9.3	41.4	55.0	82.6	124.0
350	3.1	8.4	40.3	53.6	80.4	120.7
375	0.0	7.4	38.9	51.6	77.6	116.5
400	...	6.5	36.5	48.9	73.3	109.8
425	...	5.5	35.2	46.5	70.0	105.1
450	...	4.6	33.7	45.1	67.7	101.4
475	...	3.7	27.9	37.1	55.7	83.6
500	...	2.8	21.4	28.5	42.8	64.1
538	...	1.4	13.7	18.3	27.4	41.1
550	12.0	16.1	24.1	36.1
575	8.9	11.8	17.8	26.7
600	6.2	8.3	12.5	18.7
625	4.0	5.3	8.0	12.0
650	2.4	3.2	4.7	7.1

NOTES:

(1) Use normalized and tempered material only.

(2) The deliberate addition of any element not listed in ASTM A217, Table 1 is prohibited, except that calcium (Ca) and manganese (Mn) may be added for deoxidation.

Table 12C Pressure–Temperature Ratings for Group 1.13 Materials

Nominal Designation	Forgings		Castings			Plates
	A182 Gr. F5a		A217 Gr. C5 [Notes (1), (2)]			...
Temperature, °F	Working Pressure by Classes, psig					
	75	150	300	400	600	900
-20 to 100	145	290	750	1,000	1,500	2,250
200	130	260	750	1,000	1,500	2,250
300	115	230	730	970	1,455	2,185
400	100	200	705	940	1,410	2,115
500	85	170	665	885	1,330	1,995
600	70	140	605	805	1,210	1,815
650	60	125	590	785	1,175	1,765
700	...	110	570	755	1,135	1,705
750	...	95	530	710	1,065	1,595
800	...	80	510	675	1,015	1,525
850	...	65	485	650	975	1,460
900	...	50	375	500	745	1,120
950	...	35	275	365	550	825
1,000	...	20	200	265	400	595
1,050	145	190	290	430
1,100	100	135	200	300
1,150	60	80	125	185
1,200	35	45	70	105

NOTES:

- (1) Use normalized and tempered material only.
- (2) The deliberate addition of any element not listed in ASTM A217, Table 1 is prohibited, except that calcium (Ca) and manganese (Mn) may be added for deoxidation.

Table 13 Pressure–Temperature Ratings for Group 1.14 Materials

Nominal Designation	Forgings		Castings			Plates
	A182 Gr. F9		A217 Gr. C12 [Notes (1), (2)]			...
Temperature, °C	Working Pressure by Classes, bar					
	75	150	300	400	600	900
-29 to 38	10.0	20.0	51.7	68.9	103.4	155.1
50	9.8	19.5	51.7	68.9	103.4	155.1
100	8.8	17.7	51.5	68.7	103.0	154.6
150	7.9	15.8	50.3	66.8	100.3	150.6
200	6.9	13.8	48.6	64.8	97.2	145.8
250	6.0	12.1	46.3	61.7	92.7	139.0
300	5.1	10.2	42.9	57.0	85.7	128.6
325	4.6	9.3	41.4	55.0	82.6	124.0
350	3.1	8.4	40.3	53.6	80.4	120.7
375	...	7.4	38.9	51.6	77.6	116.5
400	...	6.5	36.5	48.9	73.3	109.8
425	...	5.5	35.2	46.5	70.0	105.1
450	...	4.6	33.7	45.1	67.7	101.4
475	...	3.7	31.7	42.3	63.4	95.1
500	...	2.8	28.2	37.6	56.5	84.7
538	...	1.4	17.5	23.3	35.0	52.5
550	15.0	20.0	30.0	45.0
575	10.5	13.9	20.9	31.4
600	7.2	9.6	14.4	21.5
625	5.0	6.6	9.9	14.9
650	3.5	4.7	7.1	10.6

NOTES:

(1) Use normalized and tempered material only.

(2) The deliberate addition of any element not listed in ASTM A217, Table 1 is prohibited, except that calcium (Ca) and manganese (Mn) may be added for deoxidation.

Table 13C Pressure–Temperature Ratings for Group 1.14 Materials

Nominal Designation	Forgings		Castings			Plates
	A182 Gr. F9		A217 Gr. C12 [Notes (1), (2)]			...
Temperature, °F	Working Pressure by Classes, psi					
	75	150	300	400	600	900
-20 to 100	145	290	750	1,000	1,500	2,250
200	130	260	750	1,000	1,500	2,250
300	115	230	730	970	1,455	2,185
400	100	200	705	940	1,410	2,115
500	85	170	665	885	1,330	1,995
600	70	140	605	805	1,210	1,815
650	60	125	590	785	1,175	1,765
700	...	110	570	755	1,135	1,705
750	...	95	530	710	1,065	1,595
800	...	80	510	675	1,015	1,525
850	...	65	485	650	975	1,460
900	...	50	450	600	900	1,350
950	...	35	375	505	755	1,130
1,000	...	20	255	340	505	760
1,050	170	230	345	515
1,100	115	150	225	340
1,150	75	100	150	225
1,200	50	70	105	155

NOTES:

- (1) Use normalized and tempered material only.
- (2) The deliberate addition of any element not listed in ASTM A217, Table 1 is prohibited, except that calcium (Ca) and manganese (Mn) may be added for deoxidation.

(20)

Table 14 Pressure–Temperature Ratings for Group 1.15 Materials

Nominal Designation	Forgings		Castings		Plates	
	Working Pressure by Classes, bar					
9Cr-1Mo-V	A182 Gr. F91 Type 1	A217 Gr. C12A [Note (1)]		A387 Gr. 91 Cl. 2		
Temperature, °C	75	150	300	400	600	900
-29 to 38	10.0	20.0	51.7	68.9	103.4	155.1
50	9.8	19.5	51.7	68.9	103.4	155.1
100	8.8	17.7	51.5	68.7	103.0	154.6
150	7.9	15.8	50.3	66.8	100.3	150.6
200	6.9	13.8	48.6	64.8	97.2	145.8
250	6.0	12.1	46.3	61.7	92.7	139.0
300	5.1	10.2	42.9	57.0	85.7	128.6
325	4.6	9.3	41.4	55.0	82.6	124.0
350	3.1	8.4	40.3	53.6	80.4	120.7
375	...	7.4	38.9	51.6	77.6	116.5
400	...	6.5	36.5	48.9	73.3	109.8
425	...	5.5	35.2	46.5	70.0	105.1
450	...	4.6	33.7	45.1	67.7	101.4
475	...	3.7	31.7	42.3	63.4	95.1
500	...	2.8	28.2	37.6	56.5	84.7
538	...	1.4	25.2	33.4	50.0	75.2
550	25.0	33.3	49.8	74.8
575	24.0	31.9	47.9	71.8
600	18.6	24.8	37.2	55.9
625	12.6	16.8	25.2	37.9
650	8.2	11.0	16.5	24.7

NOTE: (1) The deliberate addition of any element not listed in ASTM A217, Table 1 is prohibited, except that calcium (Ca) and manganese (Mn) may be added for deoxidation.

Table 14C Pressure–Temperature Ratings for Group 1.15 Materials

(20)

Nominal Designation	Forgings		Castings		Plates	
	A182 Gr. F91 Type 1		A217 Gr. C12A [Note (1)]		A387 Gr. 91 Cl. 2	
Temperature, °F	Working Pressure by Classes, psig					
	75	150	300	400	600	900
-20 to 100	145	290	750	1,000	1,500	2,250
200	130	260	750	1,000	1,500	2,250
300	115	230	730	970	1,455	2,185
400	100	200	705	940	1,410	2,115
500	85	170	665	885	1,330	1,995
600	70	140	605	805	1,210	1,815
650	60	125	590	785	1,175	1,765
700	...	110	570	755	1,135	1,705
750	...	95	530	710	1,065	1,595
800	...	80	510	675	1,015	1,525
850	...	65	485	650	975	1,460
900	...	50	450	600	900	1,350
950	...	35	385	515	775	1,160
1,000	...	20	365	485	725	1,090
1,050	...	20	360	480	720	1,080
1,100	300	400	600	895
1,150	195	260	390	585
1,200	120	160	240	360

NOTE: (1) The deliberate addition of any element not listed in ASTM A217, Table 1 is prohibited, except that calcium (Ca) and manganese (Mn) may be added for deoxidation.

Table 15 Pressure–Temperature Ratings for Group 1.17 Materials

Nominal Designation	Forgings		Castings			Plates
1Cr- $\frac{1}{2}$ Mo	A182 Gr. F12 Cl. 2 [Notes (1), (2)]			
5Cr- $\frac{1}{2}$ Mo	A182 Gr. F5			
Working Pressure by Classes, bar						
Temperature, °C	75	150	300	400	600	900
-29 to 38	9.9	19.8	51.7	68.9	103.4	155.1
50	9.8	19.5	51.5	68.7	103.0	154.5
100	8.8	17.7	50.4	67.3	100.9	151.3
150	7.9	15.8	48.2	64.2	96.4	144.5
200	6.9	13.8	46.3	61.7	92.5	138.8
250	6.0	12.1	44.8	59.8	89.6	134.5
300	5.1	10.2	42.9	57.0	85.7	128.6
325	4.6	9.3	41.4	55.0	82.6	124.0
350	3.1	8.4	40.3	53.6	80.4	120.7
375	...	7.4	38.9	51.6	77.6	116.5
400	...	6.5	36.5	48.9	73.3	109.8
425	...	5.5	35.2	46.5	70.0	105.1
450	...	4.6	33.7	45.1	67.7	101.4
475	...	3.7	27.9	37.1	55.7	83.6
500	...	2.8	21.4	28.5	42.8	64.1
538	...	1.4	13.7	18.3	27.4	41.1
550	12.0	16.1	24.1	36.1
575	8.8	11.7	17.6	26.4
600	6.1	8.1	12.1	18.2
625	4.0	5.3	8.0	12.0
650	2.4	3.2	4.7	7.1

NOTES:

(1) Use normalized and tempered material only.

(2) Permissible, but not recommended for prolonged use above 590°C.

Table 15C Pressure-Temperature Ratings for Group 1.17 Materials

Nominal Designation	Forgings		Castings			Plates
1Cr- $\frac{1}{2}$ Mo	A182 Gr. F12 Cl. 2	[Notes (1), (2)]		
5Cr- $\frac{1}{2}$ Mo	A182 Gr. F5			
Working Pressure by Classes, psig						
Temperature, °F	75	150	300	400	600	900
-20 to 100	145	290	750	1,000	1,500	2,250
200	130	260	735	980	1,470	2,210
300	115	230	700	935	1,400	2,100
400	100	200	670	890	1,335	2,005
500	85	170	645	860	1,290	1,940
600	70	140	605	805	1,210	1,815
650	60	125	590	785	1,175	1,765
700	...	110	570	755	1,135	1,705
750	...	95	530	710	1,065	1,595
800	...	80	510	675	1,015	1,525
850	...	65	485	650	975	1,460
900	...	50	375	500	745	1,120
950	...	35	275	365	550	825
1,000	...	20	200	265	400	595
1,050	145	190	290	430
1,100	95	130	190	290
1,150	60	80	125	185
1,200	35	45	70	105

NOTES:

- (1) Use normalized and tempered material only.
(2) Permissible, but not recommended for prolonged use above 1,100°F.

Table 16 Pressure–Temperature Ratings for Group 1.18 Materials

Nominal Designation	Forgings		Castings			Plates
	A182 Gr. F92 [Note (1)]	
Temperature, °C	Working Pressure by Classes, bar					
	75	150	300	400	600	900
-29 to 38	10.0	20.0	51.7	68.9	103.4	155.1
50	9.8	19.5	51.7	68.9	103.4	155.1
100	8.9	17.7	51.5	68.7	103.0	154.6
150	7.9	15.8	50.3	66.8	100.3	150.6
200	6.9	13.8	48.6	64.8	97.2	145.8
250	6.1	12.1	46.3	61.7	92.7	139.0
300	5.1	10.2	42.9	57.0	85.7	128.6
325	4.7	9.3	41.4	55.0	82.6	124.0
350	4.2	8.4	40.3	53.6	80.4	120.7
375	...	7.4	38.9	51.6	77.6	116.5
400	...	6.5	36.5	48.9	73.3	109.8
425	...	5.5	35.2	46.5	70.0	105.1
450	...	4.6	33.7	45.1	67.7	101.4
475	...	3.7	31.7	42.3	63.4	95.1
500	...	2.8	28.2	37.6	56.5	84.7
538	...	1.4	25.2	33.4	50.0	75.2
550	25.0	33.3	49.8	74.8
575	24.0	31.9	47.9	71.8
600	21.6	28.6	42.9	64.2
625	18.3	24.3	36.6	54.9
650	13.2	18.9	26.5	39.7

NOTE: (1) Applications above 620°C are limited to tubing of maximum outside diameter of 3½ in.

Table 16C Pressure–Temperature Ratings for Group 1.18 Materials

Nominal Designation	Forgings			Castings		Plates
	9Cr–2W–V	A182 Gr. F92 [Note (1)]		
Temperature, °F	Working Pressure by Classes, psig					
	75	150	300	400	600	900
–20 to 100	145	290	750	1,000	1,500	2,250
200	130	260	750	1,000	1,500	2,250
300	115	230	730	970	1,455	2,185
400	100	200	705	940	1,410	2,115
500	85	170	665	885	1,330	1,995
600	60	140	605	805	1,210	1,815
650	...	125	590	785	1,175	1,765
700	...	110	570	755	1,135	1,705
750	...	95	530	710	1,065	1,595
800	...	80	510	675	1,015	1,525
850	...	65	485	650	975	1,460
900	...	50	450	600	900	1,350
950	...	35	385	515	775	1,160
1,000	...	20	365	485	725	1,090
1,050	360	480	720	1,080
1,100	325	430	645	965
1,150	275	365	550	825
1,200	190	275	385	575

NOTE: (1) Applications above 1,150°F are limited to tubing of maximum outside diameter of 3½ in.

Table 17 Pressure–Temperature Ratings for Group 2.1 Materials

Nominal Designation	Forgings		Castings		Plates	
18Cr–8Ni	A182 Gr. F304 [Note (1)]		A351 Gr. CF3 [Note (2)]		A240 Gr. 304 [Note (1)]	
18Cr–8Ni	A182 Gr. F304H		A351 Gr. CF8 [Note (1)]		A240 Gr. 304H	
Working Pressure by Classes, bar						
Temperature, °C	75	150	300	400	600	900
-29 to 38	9.5	19.0	49.6	66.2	99.3	148.9
50	9.2	18.3	47.8	63.8	95.6	143.5
100	7.8	15.7	40.9	54.5	81.7	122.6
150	7.1	14.2	37.0	49.3	74.0	111.0
200	6.6	13.2	34.5	46.0	69.0	103.4
250	6.0	12.1	32.5	43.3	65.0	97.5
300	5.1	10.2	30.9	41.2	61.8	92.7
325	4.6	9.3	30.2	40.3	60.4	90.7
350	3.1	8.4	29.6	39.5	59.3	88.9
375	...	7.4	29.0	38.7	58.1	87.1
400	...	6.5	28.4	37.9	56.9	85.3
425	...	5.5	28.0	37.3	56.0	84.0
450	...	4.6	27.4	36.5	54.8	82.2
475	...	3.7	26.9	35.9	53.9	80.8
500	...	2.8	26.5	35.3	53.0	79.5
538	...	1.4	24.4	32.6	48.9	73.3
550	23.6	31.4	47.1	70.7
575	20.8	27.8	41.7	62.5
600	16.9	22.5	33.8	50.6
625	13.8	18.4	27.6	41.4
650	11.3	15.0	22.5	33.8
675	9.3	12.5	18.7	28.0
700	8.0	10.7	16.1	24.1
725	6.8	9.0	13.5	20.3
750	5.8	7.7	11.6	17.3
775	4.6	6.2	9.0	13.7
800	3.5	4.8	7.0	10.5
816	2.8	3.8	5.9	8.6

NOTES:

(1) At temperatures over 538°C, use only when the carbon content is 0.04% or higher.

(2) Not to be used over 425°C.

Table 17C Pressure–Temperature Ratings for Group 2.1 Materials

Nominal Designation	Forgings		Castings		Plates	
18Cr–8Ni	A182 Gr. F304 [Note (1)]		A351 Gr. CF3 [Note (2)]		A240 Gr. 304 [Note (1)]	
18Cr–8Ni	A182 Gr. F304H		A351 Gr. CF8 [Note (1)]		A240 Gr. 304H	
Working Pressure by Classes, psig						
Temperature, °F	75	150	300	400	600	900
–20 to 100	140	275	720	960	1,440	2,160
200	115	230	600	800	1,200	1,800
300	105	205	540	715	1,075	1,615
400	95	190	495	660	995	1,490
500	85	170	465	620	930	1,395
600	70	140	440	590	885	1,325
650	60	125	430	575	865	1,295
700	...	110	420	565	845	1,265
750	...	95	415	550	825	1,240
800	...	80	405	540	810	1,215
850	...	65	395	530	790	1,190
900	...	50	390	520	780	1,165
950	...	35	380	510	765	1,145
1,000	...	20	355	470	710	1,065
1,050	325	435	650	975
1,100	255	345	515	770
1,150	205	275	410	615
1,200	165	220	330	495
1,250	135	180	265	400
1,300	115	150	225	340
1,350	95	125	185	280
1,400	75	100	150	225
1,450	60	80	115	175
1,500	40	55	85	125

NOTES:

(1) At temperatures over 1,000°F, use only when the carbon content is 0.04% or higher.

(2) Not to be used over 800°F.

Table 18 Pressure–Temperature Ratings for Group 2.2 Materials

Nominal Designation	Forgings	Castings	Plates
16Cr–12Ni–2Mo	A182 Gr. F316 [Note (1)]	A351 Gr. CF3M [Note (2)]	A240 Gr. 316 [Note (1)]
16Cr–12Ni–2Mo	A182 Gr. F316H	A351 Gr. CF8M [Note (1)]	A240 Gr. 316H
18Cr–13Ni–3Mo	A182 Gr. F317 [Note (1)]	...	A240 Gr. 317 [Note (1)]
19Cr–10Ni–3Mo	...	A351 Gr. CG8M [Note (3)]	...

Temperature, °C	Working Pressure by Classes, bar					
	75	150	300	400	600	900
–29 to 38	9.5	19.0	49.6	66.2	99.3	148.9
50	9.2	18.4	48.1	64.2	96.2	144.3
100	8.1	16.2	42.2	56.3	84.4	126.6
150	7.4	14.8	38.5	51.3	77.0	115.5
200	6.8	13.7	35.7	47.6	71.3	107.0
250	6.0	12.1	33.4	44.5	66.8	100.1
300	5.1	10.2	31.6	42.2	63.2	94.9
325	4.6	9.3	30.9	41.2	61.8	92.7
350	3.1	8.4	30.3	40.4	60.7	91.0
375	...	7.4	29.9	39.8	59.8	89.6
400	...	6.5	29.4	39.3	58.9	88.3
425	...	5.5	29.1	38.9	58.3	87.4
450	...	4.6	28.8	38.5	57.7	86.5
475	...	3.7	28.7	38.2	57.3	86.0
500	...	2.8	28.2	37.6	56.5	84.7
538	...	1.4	25.2	33.4	50.0	75.2
550	25.0	33.3	49.8	74.8
575	24.0	31.9	47.9	71.8
600	19.9	26.5	39.8	59.7
625	15.8	21.1	31.6	47.4
650	12.7	16.9	25.3	38.0
675	10.3	13.8	20.6	31.0
700	8.4	11.2	16.8	25.1
725	7.0	9.3	14.0	21.0
750	5.9	7.8	11.7	17.6
775	4.6	6.2	9.0	13.7
800	3.5	4.8	7.0	10.5
816	2.8	3.8	5.9	8.6

NOTES:

(1) At temperatures over 538°C, use only when the carbon content is 0.04% or higher.

(2) Not to be used over 455°C.

(3) Not to be used over 538°C.

Table 18C Pressure-Temperature Ratings for Group 2.2 Materials

Nominal Designation	Forgings		Castings		Plates	
16Cr-12Ni-2Mo	A182 Gr. F316 [Note (1)]		A351 Gr. CF3M [Note (2)]		A240 Gr. 316 [Note (1)]	
16Cr-12Ni-2Mo	A182 Gr. F316H		A351 Gr. CF8M [Note (1)]		A240 Gr. 316H	
18Cr-13Ni-3Mo	A182 Gr. F317 [Note (1)]		...		A240 Gr. 317 [Note (1)]	
19Cr-10Ni-3Mo	...		A351 Gr. CG8M [Note (3)]		...	
Working Pressure by Classes, psig						
Temperature, °F	75	150	300	400	600	900
-20 to 100	140	275	720	960	1,440	2,160
200	120	235	620	825	1,240	1,860
300	105	215	560	745	1,120	1,680
400	100	195	515	685	1,025	1,540
500	85	170	480	635	955	1,435
600	70	140	450	600	900	1,355
650	60	125	440	590	885	1,325
700	...	110	435	580	870	1,305
750	...	95	425	570	855	1,280
800	...	80	420	565	845	1,265
850	...	65	420	555	835	1,255
900	...	50	415	555	830	1,245
950	...	35	385	515	775	1,160
1,000	...	20	365	485	725	1,090
1,050	360	480	720	1,080
1,100	305	405	610	915
1,150	235	315	475	710
1,200	185	245	370	555
1,250	145	195	295	440
1,300	115	155	235	350
1,350	95	130	190	290
1,400	75	100	150	225
1,450	60	80	115	175
1,500	40	55	85	125

NOTES:

- (1) At temperatures over 1,000°F, use only when the carbon content is 0.04% or higher.
(2) Not to be used over 850°F.
(3) Not to be used over 1,000°F.

Table 19 Pressure–Temperature Ratings for Group 2.3 Materials

Nominal Designation	Forgings	Castings	Plates			
18Cr–8Ni	A182 Gr. F304L [Note (1)]	...	A240 Gr. 304L [Note (1)]			
16Cr–12Ni–2Mo	A182 Gr. F316L	...	A240 Gr. 316L			
18Cr–13Ni–3Mo	A182 Gr. F317L			
Working Pressure by Classes, bar						
Temperature, °C	75	150	300	400	600	900
–29 to 38	7.9	15.9	41.4	55.2	82.7	124.1
50	7.7	15.3	40.0	53.4	80.0	120.1
100	6.7	13.3	34.8	46.4	69.6	104.4
150	6.0	12.0	31.4	41.9	62.8	94.2
200	5.6	11.2	29.2	38.9	58.3	87.5
250	5.3	10.5	27.5	36.6	54.9	82.4
300	5.0	10.0	26.1	34.8	52.1	78.2
325	4.6	9.3	25.5	34.0	51.0	76.4
350	3.1	8.4	25.1	33.4	50.1	75.2
375	...	7.4	24.8	33.0	49.5	74.3
400	...	6.5	24.3	32.4	48.6	72.9
425	...	5.5	23.9	31.8	47.7	71.6
450	...	4.6	23.4	31.2	46.8	70.2

NOTE:

(1) Not to be used over 425°C.

Table 19C Pressure–Temperature Ratings for Group 2.3 Materials

Nominal Designation	Forgings	Castings			Plates	
18Cr–8Ni	A182 Gr. F304L [Note (1)]	...			A240 Gr. 304L [Note (1)]	
16Cr–12Ni–2Mo	A182 Gr. F316L	...			A240 Gr. 316L	
18Cr–13Ni–3Mo	A182 Gr. 317L	
Working Pressure by Classes, psig						
Temperature, °F	75	150	300	400	600	900
–20 to 100	115	230	600	800	1,200	1,800
200	100	195	510	680	1,020	1,535
300	85	175	455	610	910	1,370
400	80	160	420	560	840	1,260
500	75	150	395	525	785	1,180
600	70	140	370	495	745	1,115
650	60	125	365	485	730	1,095
700	...	110	360	480	720	1,080
750	...	95	355	470	705	1,060
800	...	80	345	460	690	1,035
850	...	65	340	450	675	1,015

NOTE:

(1) Not to be used over 800°F.

Table 20 Pressure–Temperature Ratings for Group 2.4 Materials

Nominal Designation	Forgings		Castings		Plates	
18Cr–10Ni–Ti	A182 Gr. F321 [Note (1)]		...		A240 Gr. 321 [Note (1)]	
18Cr–10Ni–Ti	A182 Gr. F321H [Note (2)]		...		A240 Gr. 321H [Note (2)]	
Working Pressure by Classes, bar						
Temperature, °C	75	150	300	400	600	900
–29 to 38	9.5	19.0	49.6	66.2	99.3	148.9
50	9.3	18.6	48.6	64.7	97.1	145.7
100	8.5	17.0	44.2	59.0	88.5	132.7
150	7.9	15.7	41.0	54.6	82.0	122.9
200	6.9	13.8	38.3	51.1	76.6	114.9
250	6.0	12.1	36.0	48.0	72.0	108.1
300	5.1	10.2	34.1	45.5	68.3	102.4
325	4.6	9.3	33.3	44.4	66.6	99.9
350	3.1	8.4	32.6	43.5	65.2	97.8
375	...	7.4	32.0	42.7	64.1	96.1
400	...	6.5	31.6	42.1	63.2	94.8
425	...	6.5	31.1	41.5	62.3	93.4
450	...	4.6	30.8	41.1	61.7	92.5
475	...	3.7	30.5	40.7	61.1	91.6
500	...	2.8	28.2	37.6	56.5	84.7
538	...	1.4	25.2	33.4	50.0	75.2
550	25.0	33.3	49.8	74.8
575	24.0	31.9	47.9	71.8
600	20.3	27.0	40.5	60.8
625	15.8	21.1	31.6	47.4
650	12.6	16.9	25.3	37.9
675	9.9	13.2	19.8	29.6
700	7.9	10.5	15.8	23.7
725	6.3	8.5	12.7	19.0
750	5.0	6.7	10.0	15.0
775	4.0	5.3	8.0	11.9
800	3.1	4.2	6.3	9.4
816	2.6	3.5	5.2	7.8

NOTES:

(1) Not to be used over 538°C.

(2) At temperatures over 538°C, use only if the material is heat treated by heating to a minimum temperature of 1 095°C.

Table 20C Pressure–Temperature Ratings for Group 2.4 Materials

Nominal Designation	Forgings		Castings		Plates	
18Cr–10Ni–Ti	A182 Gr. F321	[Note (1)]	A240 Gr. 321	[Note (1)]
18Cr–10Ni–Ti	A182 Gr. F321H	[Note (2)]	A240 Gr. 321H	[Note (2)]
Working Pressure by Classes, psig						
Temperature, °F	75	150	300	400	600	900
–20 to 100	140	275	720	960	1,440	2,160
200	125	250	650	865	1,295	1,945
300	115	230	595	795	1,190	1,785
400	100	200	550	735	1,105	1,655
500	85	170	515	690	1,030	1,550
600	70	140	485	650	975	1,460
650	60	125	475	635	950	1,425
700	...	110	465	620	930	1,395
750	...	95	460	610	915	1,375
800	...	80	450	600	900	1,355
850	...	65	445	595	895	1,340
900	...	50	440	590	885	1,325
950	...	35	385	515	775	1,160
1,000	...	20	365	485	725	1,090
1,050	360	480	720	1,080
1,100	310	415	625	935
1,150	235	315	475	710
1,200	185	245	370	555
1,250	140	185	280	420
1,300	110	145	220	330
1,350	85	115	170	255
1,400	65	85	130	195
1,450	50	70	105	155
1,500	40	50	75	115

NOTES:

(1) Not to be used over 1,000°F.

(2) At temperatures over 1,000°F, use only if the material is heat treated by heating to a minimum temperature of 2,000°F.

Table 21 Pressure–Temperature Ratings for Group 2.5 Materials

Nominal Designation	Forgings		Castings		Plates	
18Cr–10Ni–Cb	A182 Gr. F347 [Note (1)]		...		A240 Gr. 347 [Note (1)]	
18Cr–10Ni–Cb	A182 Gr. F347H [Note (2)]		...		A240 Gr. 347H [Note (2)]	
18Cr–10Ni–Cb	A182 Gr. F348 [Note (1)]		...		A240 Gr. 348 [Note (1)]	
18Cr–10Ni–Cb	A182 Gr. F348H [Note (2)]		...		A240 Gr. 348H [Note (2)]	
Working Pressure by Classes, bar						
Temperature, °C	75	150	300	400	600	900
–29 to 38	9.5	19.0	49.6	66.2	99.3	148.9
50	9.3	18.7	48.8	65.0	97.5	146.3
100	8.7	17.4	45.3	60.4	90.6	135.9
150	7.9	15.8	42.5	56.6	84.9	127.4
200	6.9	13.8	39.9	53.3	79.9	119.8
250	6.0	12.1	37.8	50.4	75.6	113.4
300	5.1	10.2	36.1	48.1	72.2	108.3
325	4.6	9.3	35.4	47.1	70.7	106.1
350	3.1	8.4	34.8	46.3	69.5	104.3
375	...	7.4	34.2	45.6	68.4	102.6
400	...	6.5	33.9	45.2	67.8	101.7
425	...	5.5	33.6	44.8	67.2	100.8
450	...	4.6	33.5	44.6	66.9	100.4
475	...	3.7	31.7	42.3	63.4	95.1
500	...	2.8	28.2	37.6	56.5	84.7
538	...	1.4	25.2	33.4	50.0	75.2
550	25.0	33.3	49.8	74.8
575	24.0	31.9	47.9	71.8
600	21.6	28.6	42.9	64.2
625	18.3	24.3	36.6	54.9
650	14.1	18.9	28.1	42.5
675	12.4	16.9	25.2	37.6
700	10.1	13.4	20.0	29.8
725	7.9	10.5	15.4	23.2
750	5.9	7.9	11.7	17.6
775	4.6	6.2	9.0	13.7
800	3.5	4.8	7.0	10.5
816	2.8	3.8	5.9	8.6

NOTES:

(1) Not to be used over 538°C.

(2) For temperatures over 538°C, use only if the material is heat treated by heating to a minimum temperature of 1 095°C.

Table 21C Pressure-Temperature Ratings for Group 2.5 Materials

Nominal Designation	Forgings		Castings		Plates	
18Cr-10Ni-Cb	A182 Gr. F347	[Note (1)]	A240 Gr. 347	[Note (1)]
18Cr-10Ni-Cb	A182 Gr. F347H	[Note (2)]	A240 Gr. 347H	[Note (2)]
18Cr-10Ni-Cb	A182 Gr. F348	[Note (1)]	A240 Gr. 348	[Note (1)]
18Cr-10Ni-Cb	A182 Gr. F348H	[Note (2)]	A240 Gr. 348H	[Note (2)]

Temperature, °F	Working Pressure by Classes, psig					
	75	150	300	400	600	900
-20 to 100	140	275	720	960	1,440	2,160
200	125	255	660	885	1,325	1,985
300	115	230	615	820	1,235	1,850
400	100	200	575	770	1,150	1,730
500	85	170	540	725	1,085	1,625
600	70	140	515	690	1,030	1,550
650	60	125	505	675	1,015	1,520
700	...	110	495	660	995	1,490
750	...	95	490	655	985	1,475
800	...	80	485	650	975	1,460
850	...	65	485	645	970	1,455
900	...	50	450	600	900	1,350
950	...	35	385	515	775	1,160
1,000	...	20	365	485	725	1,090
1,050	360	480	720	1,080
1,100	325	430	645	965
1,150	275	365	550	825
1,200	205	275	410	620
1,250	180	245	365	545
1,300	140	185	275	410
1,350	105	140	205	310
1,400	75	100	150	225
1,450	60	80	115	175
1,500	40	55	85	125

NOTES:

(1) Not to be used over 1,000°F.

(2) For temperatures over 1,000°F, use only if the material is heat treated by heating to a minimum temperature of 2,000°F.

Table 22 Pressure–Temperature Ratings for Group 2.6 Materials

Nominal Designation	Forgings		Castings		Plates	
	Working Pressure by Classes, bar					
Temperature, °C	75	150	300	400	600	900
23Cr–12Ni	A240 Gr. 309H	
–29 to 38	9.5	19.0	49.6	66.2	99.3	148.9
50	9.3	18.5	48.3	64.4	96.6	144.9
100	8.3	16.5	43.1	57.5	86.2	129.3
150	7.7	15.3	40.0	53.3	80.0	120.0
200	6.9	13.8	37.8	50.3	75.5	113.3
250	6.0	12.1	36.1	48.1	72.1	108.2
300	5.1	10.2	34.8	46.4	69.6	104.4
325	4.6	9.3	34.2	45.7	68.5	102.7
350	3.1	8.4	33.8	45.1	67.6	101.4
375	...	7.4	33.4	44.5	66.8	100.1
400	...	6.5	33.1	44.1	66.1	99.2
425	...	5.5	32.6	43.5	65.3	97.9
450	...	4.6	32.2	42.9	64.4	96.5
475	...	3.7	31.7	42.3	63.4	95.1
500	...	2.8	28.2	37.6	56.5	84.7
538	...	1.4	25.2	33.4	50.0	75.2
550	25.0	33.3	49.8	74.8
575	22.2	29.6	44.4	66.5
600	16.8	22.4	33.5	50.3
625	12.5	16.7	25.0	37.5
650	9.4	12.5	18.7	28.1
675	7.2	9.6	14.5	21.7
700	5.5	7.3	11.0	16.5
725	4.3	5.8	8.7	13.0
750	3.4	4.6	6.8	10.2
775	2.7	3.6	5.4	8.1
800	2.1	2.8	4.2	6.3
816	1.8	2.4	3.5	5.3

Table 22C Pressure–Temperature Ratings for Group 2.6 Materials

Nominal Designation	Forgings		Castings		Plates	
	Working Pressure by Classes, psig					
Temperature, °F	75	150	300	400	600	900
23Cr–12Ni		A240 Gr. 309H	
-20 to 100	140	275	720	960	1,440	2,160
200	120	240	630	840	1,260	1,895
300	110	225	580	775	1,160	1,740
400	100	200	545	725	1,090	1,635
500	85	170	520	690	1,035	1,555
600	70	140	500	665	1,000	1,500
650	60	125	490	655	985	1,475
700	...	110	485	645	970	1,455
750	...	95	480	640	960	1,440
800	...	80	475	630	945	1,420
850	...	65	465	620	930	1,395
900	...	50	450	600	900	1,350
950	...	35	385	515	775	1,160
1,000	...	20	365	485	725	1,090
1,050	355	470	705	1,060
1,100	260	345	520	780
1,150	190	250	375	565
1,200	135	185	275	410
1,250	105	135	205	310
1,300	75	100	150	225
1,350	60	80	115	175
1,400	45	60	90	135
1,450	35	45	70	105
1,500	25	35	50	75

Table 23 Pressure–Temperature Ratings for Group 2.7 Materials

Nominal Designation	Forgings		Castings		Plates	
	A182 Gr. F310 [Notes (1), (2)]		...		A240 Gr. 310H	
Temperature, °C	Working Pressure by Classes, bar					
	75	150	300	400	600	900
-29 to 38	9.5	19.0	49.6	66.2	99.3	148.9
50	9.3	18.5	48.4	64.5	96.7	145.1
100	8.3	16.6	43.4	57.9	86.8	130.2
150	7.7	15.3	40.0	53.3	80.0	120.0
200	6.9	13.8	37.6	50.1	75.2	112.8
250	6.0	12.1	35.8	47.7	71.5	107.3
300	5.1	10.2	34.5	45.9	68.9	103.4
325	4.6	9.3	33.9	45.2	67.7	101.6
350	3.1	8.4	33.3	44.4	66.6	99.9
375	...	7.4	32.9	43.8	65.7	98.6
400	...	6.5	32.4	43.2	64.8	97.3
425	...	5.5	32.1	42.8	64.2	96.4
450	...	4.6	31.7	42.2	63.4	95.1
475	...	3.7	31.2	41.7	62.5	93.7
500	...	2.8	28.2	37.6	56.5	84.7
538	...	1.4	25.2	33.4	50.0	75.2
550	25.0	33.3	49.8	74.8
575	22.2	29.6	44.4	66.5
600	16.8	22.4	33.5	50.3
625	12.5	16.7	25.0	37.5
650	9.4	12.5	18.7	28.1
675	7.2	9.6	14.5	21.7
700	5.5	7.3	11.0	16.5
725	4.3	5.8	8.7	13.0
750	3.4	4.6	6.8	10.2
775	2.7	3.5	5.3	8.0
800	2.1	2.8	4.1	6.2
816	1.8	2.4	3.5	5.3

NOTES:

(1) At temperatures over 538°C, use only when the carbon content is 0.04% or higher.

(2) Service temperatures of 565°C and above should be used only when assurance is provided that grain size is not finer than ASTM 6.

Table 23C Pressure–Temperature Ratings for Group 2.7 Materials

Nominal Designation	Forgings		Castings		Plates	
	A182 Gr. F310 [Notes (1), (2)]		...		A240 Gr. 310H	
Temperature, °F	Working Pressure by Classes, psig					
	75	150	300	400	600	900
-20 to 100	140	275	720	960	1,440	2,160
200	120	245	635	850	1,270	1,910
300	110	225	580	775	1,160	1,740
400	100	200	540	725	1,085	1,625
500	85	170	515	685	1,025	1,540
600	70	140	495	660	990	1,485
650	60	125	485	645	970	1,455
700	...	110	480	635	955	1,435
750	...	95	470	625	940	1,410
800	...	80	465	620	930	1,395
850	...	65	460	610	915	1,375
900	...	50	450	600	900	1,350
950	...	35	385	515	775	1,160
1,000	...	20	365	485	725	1,090
1,050	355	470	705	1,060
1,100	260	345	520	780
1,150	190	250	375	565
1,200	135	185	275	410
1,250	105	135	205	310
1,300	75	100	150	225
1,350	60	80	115	175
1,400	45	60	90	135
1,450	35	45	65	100
1,500	25	35	50	75

NOTES:

- (1) At temperatures over 1,000°F, use only when the carbon content is 0.04% or higher.
- (2) Service temperatures of 1,050°F and above should be used only when assurance is provided that grain size is not finer than ASTM 6.

Table 24 Pressure–Temperature Ratings for Group 2.8 Materials

Nominal Designation	Forgings		Castings		Plates	
20Cr–18Ni–6Mo	A182 Gr. F44		A351 Gr. CK3MCuN		A240 Gr. S31254	
22Cr–5Ni–3Mo–N	A182 Gr. F51 [Note (1)]		...		A240 Gr. S31803 [Note (1)]	
25Cr–7Ni–4Mo–N	A182 Gr. F53 [Note (1)]		...		A240 Gr. S32750 [Note (1)]	
24Cr–10Ni–4Mo–V	...		A351 Gr. CE8MN [Note (1)]		...	
25Cr–5Ni–2Mo–3Cu	...		A995 Gr. CD4MCu [Note (1)]		...	
25Cr–7Ni–3.5Mo–W–Cb	...		A995 Gr. CD3MWCuN [Note (1)]		...	
25Cr–7Ni–3.5Mo–N–Cu–W	A182 Gr. F55 [Note (1)]		...		A240 Gr. S32760 [Note (1)]	
Working Pressure by Classes, bar						
Temperature, °C	75	150	300	400	600	900
–29 to 38	10.0	20.0	51.7	68.9	103.4	155.1
50	9.8	19.5	51.7	68.9	103.4	155.1
100	8.8	17.7	50.7	67.5	101.3	152.0
150	7.9	15.8	45.9	61.2	91.9	137.8
200	6.9	13.8	42.7	56.9	85.3	128.0
250	6.0	12.1	40.5	53.9	80.9	121.4
300	5.1	10.2	38.9	51.8	77.7	116.6
325	4.6	9.3	38.2	50.9	76.3	114.5
350	3.1	8.4	37.6	50.2	75.3	112.9
375	...	7.4	37.4	49.8	74.7	112.1
400	...	6.5	36.5	48.9	73.3	109.8

NOTE:

(1) This steel may become brittle after service at moderately elevated temperatures. Not to be used over 315°C.

Table 24C Pressure–Temperature Ratings for Group 2.8 Materials

Nominal Designation	Forgings		Castings		Plates	
20Cr–18Ni–6Mo	A182 Gr. F44		A351 Gr. CK3MCuN		A240 Gr. S31254	
22Cr–5Ni–3Mo–N	A182 Gr. F51 [Note (1)]		...		A240 Gr. S31803 [Note (1)]	
25Cr–7Ni–4Mo–N	A182 Gr. F53 [Note (1)]		...		A240 Gr. S32750 [Note (1)]	
24Cr–10Ni–4Mo–V	...		A351 Gr. CE8MN [Note (1)]		...	
25Cr–5Ni–2Mo–3Cu	...		A995 Gr. CD4MCu [Note (1)]		...	
25Cr–7Ni–3.5Mo–W–Cb	...		A995 Gr. CD3MWCuN [Note (1)]		...	
25Cr–7Ni–3.5Mo–N–Cu–W	A182 Gr. F55 [Note (1)]		...		A240 Gr. S32760 [Note (1)]	
Working Pressure by Classes, psig						
Temperature, °F	75	150	300	400	600	900
–20 to 100	145	290	750	1,000	1,500	2,250
200	130	260	745	990	1,490	2,230
300	115	230	665	890	1,335	2,000
400	100	200	615	820	1,230	1,845
500	85	170	580	775	1,160	1,740
600	70	140	555	740	1,115	1,670
650	60	125	545	730	1,095	1,640
700	...	110	540	725	1,085	1,625
750	...	95	530	710	1,065	1,595

NOTE:

(1) This steel may become brittle after service at moderately elevated temperatures. Not to be used over 600°F.

Table 25 Pressure–Temperature Ratings for Group 2.9 Materials

Nominal Designation	Forgings		Castings		Plates	
23Cr–12Ni		A240 Gr. 309S	[Notes (1)–(3)]
25Cr–20Ni		A240 Gr. 310S	[Notes (1)–(3)]
Working Pressure by Classes, bar						
Temperature, °C	75	150	300	400	600	900
–29 to 38	9.5	19.0	49.6	66.2	99.3	148.9
50	9.3	18.5	48.3	64.4	96.6	144.9
100	8.3	16.5	43.1	57.5	86.2	129.3
150	7.7	15.3	40.0	53.3	80.0	120.0
200	6.9	13.8	37.6	50.1	75.2	112.8
250	6.0	12.1	35.8	47.7	71.5	107.3
300	5.1	10.2	34.5	45.9	68.9	103.4
325	4.6	9.3	33.9	45.2	67.7	101.6
350	3.1	8.4	33.3	44.4	66.6	99.9
375	...	7.4	32.9	43.8	65.7	98.6
400	...	6.5	32.4	43.2	64.8	97.3
425	...	5.5	32.1	42.8	64.2	96.4
450	...	4.6	31.7	42.2	63.4	95.1
475	...	3.7	31.2	41.7	62.5	93.7
500	...	2.8	28.2	37.6	56.5	84.7
538	...	1.4	23.4	31.2	46.8	70.2
550	20.5	27.3	41.0	61.5
575	15.1	20.1	30.2	45.3
600	11.0	14.7	22.1	33.1
625	8.1	10.9	16.3	24.4
650	5.8	7.8	11.6	17.4
675	3.7	4.9	7.4	11.1
700	2.2	2.9	4.3	6.5
725	1.4	1.8	2.7	4.1
750	1.0	1.4	2.1	3.1
775	0.8	1.1	1.6	2.5
800	0.6	0.8	1.2	1.8
816	0.5	0.6	0.9	1.4

NOTES:

- (1) At temperatures over 538°C, use only when the carbon content is 0.04% or higher.
- (2) At temperatures above 538°C, use only if the material is solution heat treated to the minimum temperature specified in the specification, but not lower than 1 035°C, and quenching in water or rapidly cooling by other means.
- (3) This material should be used for service temperatures 565°C and above only when assurance is provided that grain size is not finer than ASTM 6.

Table 25C Pressure–Temperature Ratings for Group 2.9 Materials

Nominal Designation	Forgings		Castings		Plates	
23Cr–12Ni		A240 Gr. 309S [Notes (1)–(3)]	
25Cr–20Ni		A240 Gr. 310S [Notes (1)–(3)]	
Working Pressure by Classes, psig						
Temperature, °F	75	150	300	400	600	900
–20 to 100	140	275	720	960	1,440	2,160
200	120	240	630	840	1,260	1,895
300	110	225	580	775	1,160	1,740
400	100	200	540	725	1,085	1,625
500	85	170	515	685	1,025	1,540
600	70	140	495	660	990	1,485
650	60	125	485	645	970	1,455
700	...	110	480	635	955	1,435
750	...	95	470	625	940	1,410
800	...	80	465	620	930	1,395
850	...	65	460	610	915	1,375
900	...	50	450	600	900	1,350
950	...	35	385	515	775	1,160
1,000	...	20	340	455	680	1,020
1,050	245	325	485	730
1,100	170	230	345	515
1,150	125	165	245	370
1,200	85	115	170	255
1,250	50	70	105	155
1,300	25	35	55	80
1,350	15	25	35	50
1,400	15	20	25	40
1,450	10	15	20	30
1,500	5	10	15	20

NOTES:

- (1) At temperatures over 1,000°F, use only when the carbon content is 0.04% or higher.
- (2) At temperatures above 1,000°F, use only if the material is solution heat treated to the minimum temperature specified in the specification, but not lower than 1,900°F, and quenching in water or rapidly cooling by other means.
- (3) This material should be used for service temperatures 1,050°F and above only when assurance is provided that grain size is not finer than ASTM 6.

Table 26 Pressure–Temperature Ratings for Group 2.10 Materials

Nominal Designation	Forgings	Castings				Plates
25Cr–12Ni	...	A351 Gr. CH8 [Note (1)]				...
25Cr–12Ni	...	A351 Gr. CH20 [Note (1)]				...
Working Pressure by Classes, bar						
Temperature, °C	75	150	300	400	600	900
–29 to 38	8.9	17.8	46.3	61.8	92.7	139.0
50	8.5	17.0	44.5	59.3	89.0	133.4
100	7.2	14.4	37.5	50.0	75.1	112.6
150	6.7	13.4	34.9	46.5	69.8	104.7
200	6.4	12.9	33.5	44.7	67.1	100.6
250	6.0	12.1	32.6	43.5	65.2	97.8
300	5.1	10.2	31.7	42.3	63.4	95.2
325	4.6	9.3	31.2	41.6	62.4	93.6
350	3.1	8.4	30.6	40.8	61.2	91.7
375	...	7.4	29.8	39.8	59.7	89.5
400	...	6.5	29.1	38.8	58.2	87.3
425	...	5.5	28.3	37.8	56.7	85.0
450	...	4.6	27.6	36.8	55.2	82.8
475	...	3.7	26.7	35.6	53.5	80.2
500	...	2.8	25.8	34.5	51.7	77.5
538	...	1.4	23.3	31.1	46.6	70.0
550	21.9	29.2	43.8	65.7
575	18.5	24.6	37.0	55.5
600	14.5	19.4	29.0	43.5
625	11.4	15.2	22.8	34.3
650	8.9	11.9	17.8	26.7
675	7.0	9.3	14.0	20.9
700	5.7	7.6	11.3	17.0
725	4.6	6.1	9.1	13.7
750	3.5	4.7	7.0	10.5
775	2.6	3.4	5.1	7.7
800	2.0	2.7	4.0	6.1
816	1.9	2.5	3.8	5.7

NOTE: (1) At temperatures over 538°C, use only when the carbon content is 0.04% or higher.

Table 26C Pressure–Temperature Ratings for Group 2.10 Materials

Nominal Designation	Forgings		Castings			Plates
25Cr–12Ni	...		A351 Gr. CH8 [Note (1)]			...
25Cr–12Ni	...		A351 Gr. CH20 [Note (1)]			...
Working Pressure by Classes, psig						
Temperature, °F	75	150	300	400	600	900
–20 to 100	130	260	670	895	1,345	2,015
200	105	210	550	735	1,100	1,650
300	95	195	505	675	1,015	1,520
400	95	185	485	645	970	1,455
500	85	170	470	625	940	1,410
600	70	140	455	610	910	1,370
650	60	125	445	595	895	1,340
700	...	110	435	580	870	1,305
750	...	95	420	565	845	1,265
800	...	80	410	545	820	1,230
850	...	65	400	530	795	1,195
900	...	50	385	510	770	1,150
950	...	35	370	495	740	1,110
1,000	...	20	340	450	675	1,015
1,050	290	390	585	875
1,100	225	295	445	670
1,150	170	230	345	515
1,200	130	175	260	390
1,250	100	135	200	300
1,300	80	105	160	235
1,350	60	80	125	165
1,400	45	60	90	135
1,450	30	40	60	95
1,500	25	35	55	80

NOTE: (1) At temperatures over 1,000°F, use only when the carbon content is 0.04% or higher.

Table 27 Pressure–Temperature Ratings for Group 2.11 Materials

Nominal Designation	Forgings		Castings			Plates
	Working Pressure by Classes, bar					
Temperature, °C	75	150	300	400	600	900
18Cr–10Ni–Cb	...				A351 Gr. CF8C [Note (1)]	...
–29 to 38	9.5	19.0	49.6	66.2	99.3	148.9
50	9.3	18.7	48.8	65.0	97.5	146.3
100	8.7	17.4	45.3	60.4	90.6	135.9
150	7.9	15.8	42.5	56.6	84.9	127.4
200	6.9	13.8	39.9	53.3	79.9	119.8
250	6.0	12.1	37.8	50.4	75.6	113.4
300	5.1	10.2	36.1	48.1	72.2	108.3
325	4.6	9.3	35.4	47.1	70.7	106.1
350	3.1	8.4	34.8	46.3	69.5	104.3
375	...	7.4	34.2	45.6	68.4	102.6
400	...	6.5	33.9	45.2	67.8	101.7
425	...	5.5	33.6	44.8	67.2	100.8
450	...	4.6	33.5	44.6	66.9	100.4
475	...	3.7	31.7	42.3	63.4	95.1
500	...	2.8	28.2	37.6	56.5	84.7
538	...	1.4	25.2	33.4	50.0	75.2
550	25.0	33.3	49.8	74.8
575	24.0	31.9	47.9	71.8
600	19.8	26.4	39.6	59.4
625	13.9	18.5	27.7	41.6
650	10.3	13.7	20.6	30.9
675	8.0	10.6	15.9	23.9
700	5.6	7.5	11.2	16.8
725	4.0	5.3	8.0	11.9
750	3.1	4.1	6.2	9.3
775	2.5	3.3	4.9	7.4
800	2.0	2.7	4.0	6.1
816	1.9	2.5	3.8	5.7

NOTE: (1) At temperatures over 538°C, use only when the carbon content is 0.04% or higher.

Table 27C Pressure–Temperature Ratings for Group 2.11 Materials

Nominal Designation	Forgings		Castings			Plates
	Working Pressure by Classes, psig					
Temperature, °F	75	150	300	400	600	900
18Cr–10Ni–Cb	...				A351 Gr. CF8C [Note (1)]	...
–20 to 100	140	275	720	960	1,440	2,160
200	125	255	660	885	1,325	1,985
300	115	230	615	820	1,235	1,850
400	100	200	575	770	1,150	1,730
500	85	170	540	725	1,085	1,625
600	70	140	515	690	1,030	1,550
650	60	125	505	675	1,015	1,520
700	...	110	495	660	995	1,490
750	...	95	490	655	985	1,475
800	...	80	485	650	975	1,460
850	...	65	485	645	970	1,455
900	...	50	450	600	900	1,350
950	...	35	385	515	775	1,160
1,000	...	20	365	485	725	1,090
1,050	360	480	720	1,080
1,100	310	415	625	935
1,150	210	280	420	625
1,200	150	200	300	455
1,250	115	150	225	340
1,300	75	100	150	225
1,350	50	70	105	155
1,400	40	55	80	125
1,450	30	40	60	95
1,500	25	35	55	80

NOTE: (1) At temperatures over 1,000°F, use only when the carbon content is 0.04% or higher.

Table 28 Pressure–Temperature Ratings for Group 2.12 Materials

Nominal Designation	Forgings		Castings			Plates
	Working Pressure by Classes, bar					
Temperature, °C	75	150	300	400	600	900
25Cr–20Ni	...				A351 Gr. CK20 [Note (1)]	...
–29 to 38	8.9	17.8	46.3	61.8	92.7	139.0
50	8.5	17.0	44.5	59.3	89.0	133.4
100	7.2	14.4	37.5	50.0	75.1	112.6
150	6.7	13.4	34.9	46.5	69.8	104.7
200	6.4	12.9	33.5	44.7	67.1	100.6
250	6.0	12.1	32.6	43.5	65.2	97.8
300	5.1	10.2	31.7	42.3	63.4	95.2
325	4.6	9.3	31.2	41.6	62.4	93.6
350	3.1	8.4	30.6	40.8	61.2	91.7
375	...	7.4	29.8	39.8	59.7	89.5
400	...	6.5	29.1	38.8	58.2	87.3
425	...	5.5	28.3	37.8	56.7	85.0
450	...	4.6	27.6	36.8	55.2	82.8
475	...	3.7	26.7	35.6	53.5	80.2
500	...	2.8	25.8	34.5	51.7	77.5
538	...	1.4	23.3	31.1	46.6	70.0
550	22.9	30.6	45.9	68.8
575	21.7	28.9	43.3	65.0
600	19.4	25.9	38.8	58.2
625	16.8	22.4	33.7	50.5
650	14.1	18.8	28.1	42.2
675	11.5	15.4	23.0	34.6
700	8.8	11.7	17.5	26.3
725	6.3	8.5	12.7	19.0
750	4.5	6.0	8.9	13.4
775	3.1	4.2	6.3	9.4
800	2.3	3.1	4.6	6.9
816	1.9	2.5	3.8	5.7

NOTE: (1) At temperatures over 538°C, use only when the carbon content is 0.04% or higher.

Table 28C Pressure–Temperature Ratings for Group 2.12 Materials

Nominal Designation	Forgings		Castings			Plates
	Working Pressure by Classes, psig					
Temperature, °F	75	150	300	400	600	900
25Cr–20Ni	...	A351 Gr. CK20 [Note (1)]		
–20 to 100	130	260	670	895	1,345	2,015
200	105	210	550	735	1,100	1,650
300	95	195	505	675	1,015	1,520
400	95	185	485	645	970	1,455
500	85	170	470	625	940	1,410
600	70	140	455	610	910	1,370
650	60	125	445	595	895	1,340
700	...	110	435	580	870	1,305
750	...	95	420	565	845	1,265
800	...	80	410	545	820	1,230
850	...	65	400	530	795	1,195
900	...	50	385	510	770	1,150
950	...	35	370	495	740	1,110
1,000	...	20	340	450	675	1,015
1,050	325	435	650	975
1,100	290	390	585	875
1,150	250	335	500	750
1,200	205	275	410	615
1,250	165	220	330	495
1,300	120	160	240	360
1,350	60	110	165	245
1,400	55	75	110	165
1,450	40	50	75	115
1,500	25	35	55	80

NOTE: (1) At temperatures over 1,000°F, use only when the carbon content is 0.04% or higher.

(20)

Table 29 Dimensions of Ring-Joint Facings

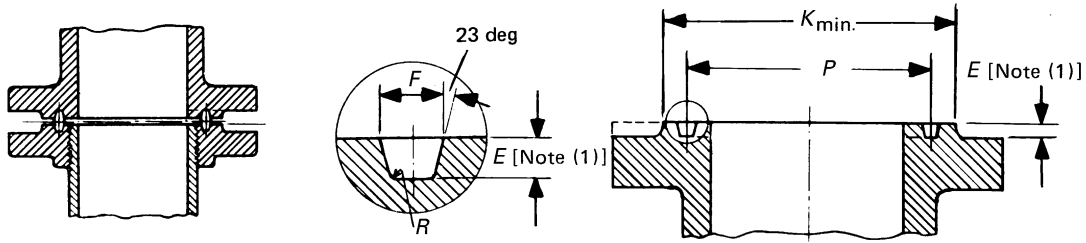

Nominal Pipe Size for Class				Groove Dimensions					Diameter of Raised Portion, <i>K</i>
300	400	600	900	Groove Number	Pitch Diameter, <i>P</i>	Depth, <i>E</i>	Width, <i>F</i>	Radius at Bottom, <i>R</i>	
26	26	26	...	R93	749.30	12.70	19.84	1.5	810
28	28	28	...	R94	800.10	12.70	19.84	1.5	861
30	30	30	...	R95	857.25	12.70	19.84	1.5	917
32	32	32	...	R96	914.40	14.27	23.01	1.5	984
34	34	34	...	R97	965.20	14.27	23.01	1.5	1 035
36	36	36	...	R98	1 022.35	14.27	23.01	1.5	1 092
...	26	R100	749.30	17.48	30.18	2.3	832
...	28	R101	800.10	17.48	33.32	2.3	889
...	30	R102	857.25	17.48	33.32	2.3	946
...	32	R103	914.40	17.48	33.32	2.3	1 003
...	34	R104	965.20	20.62	36.53	2.3	1 067
...	36	R105	1 022.35	20.62	36.53	2.3	1 124

Dimension	Tolerance
<i>E</i> (depth)	+0.41, -0.00
<i>F</i> (width)	±0.20
<i>P</i> (pitch diameter)	±0.13
<i>R</i> (radius at bottom)	+0.8, -0.0 for $R \leq 1.5$ ±0.8 for $R > 1.5$
23 deg angle	±½ deg

GENERAL NOTES:

- (a) Dimensions are in millimeters.
- (b) Ring-joint gaskets are not contemplated for NPS 38 and larger flanges.
- (c) For facing requirements for flanges, see [para. 6.1](#).
- (d) See [para. 4.2](#) for marking requirements.

NOTE: (1) Height of raised portion is equal to the depth of groove dimension *E*, but is not subjected to the tolerances for *E*. Full face contour may be used.

Table 29C Dimensions of Ring-Joint Facings

(20)

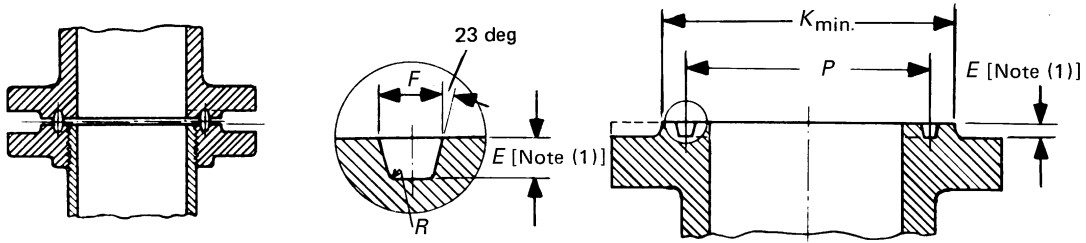

Nominal Pipe Size for Class				Groove Dimensions					Diameter of Raised Portion, <i>K</i>
300	400	600	900	Groove Number	Pitch Diameter, <i>P</i>	Depth, <i>E</i>	Width, <i>F</i>	Radius at Bottom, <i>R</i>	
26	26	26	...	R93	29.500	0.500	0.781	0.06	31.88
28	28	28	...	R94	31.500	0.500	0.781	0.06	33.88
30	30	30	...	R95	33.750	0.500	0.781	0.06	36.12
32	32	32	...	R96	36.000	0.562	0.906	0.06	38.75
34	34	34	...	R97	38.000	0.562	0.906	0.06	40.75
36	36	36	...	R98	40.250	0.562	0.906	0.06	43.00
...	26	R100	29.500	0.688	1.188	0.09	32.75
...	28	R101	31.500	0.688	1.312	0.09	35.00
...	30	R102	33.750	0.688	1.312	0.09	37.25
...	32	R103	36.000	0.688	1.312	0.09	39.50
...	34	R104	38.000	0.812	1.438	0.09	42.00
...	36	R105	40.250	0.812	1.438	0.09	44.25

Dimension	Tolerance
<i>E</i> (depth)	+0.016, -0.0
<i>F</i> (width)	±0.008
<i>P</i> (pitch diameter)	±0.005
<i>R</i> (radius at bottom)	+0.03, -0.0 for $R \leq 0.06$ ±0.03 for $R > 0.09$
23 deg angle	±1/2 deg

GENERAL NOTES:

- (a) Dimensions are in inches.
- (b) Ring-joint gaskets are not contemplated for NPS 38 and larger flanges.
- (c) For facing requirements for flanges, see para 6.1.
- (d) See para 4.2 for marking requirements.

NOTE: (1) Height of raised portion is equal to the depth of groove dimension *E*, but is not subjected to the tolerances for *E*. Full face contour may be used.

(20)

Table 30 Permissible Imperfections in Flange Facing Finish

Nominal Pipe Size	Maximum Radial Projection of Imperfections That Are No Deeper Than Bottom of Serration, mm	Maximum Depth or Maximum Radial Projection of Imperfections That Are Deeper Than Bottom of Serration, mm
26-36	12.7	6.4
38-48	14.2	7.1
50-60	15.7	7.9

GENERAL NOTE: See [para. 6.1.5](#).

(20)

Table 30C Permissible Imperfections in Flange Facing Finish

Nominal Pipe Size	Maximum Radial Projection of Imperfections That Are No Deeper Than Bottom of Serration, in.	Maximum Depth or Maximum Radial Projection of Imperfections That Are Deeper Than Bottom of Serration, in.
26-36	0.50	0.25
38-48	0.56	0.28
50-60	0.62	0.31

GENERAL NOTE: See [para. 6.1.5](#).

Table 31 Dimensions of Class 150 Series A Flanges

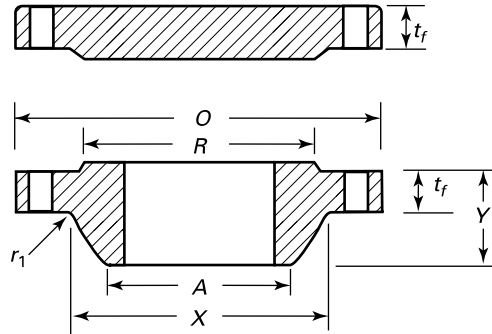

Nominal Pipe Size	O.D. of Flange, O	Minimum Thickness of Flange, t_f [Note (1)]		Length Through Hub, Y	Diam. of Hub, X [Note (2)]	Hub Diam. Top, A [Note (3)]	Raised Face Diam., R	Drilling			Minimum Fillet Radius, r_1	Length of Bolts, L [Notes (4), (5)]		
		WNF	Blind					Diam. of Bolt Circle	No. of Bolt Holes	Diam. of Bolt Hole, in.		Diam. of Bolt, in.	Stud Bolts	
													1.6 mm	Raised Face
26	870	66.8	66.8	119	676	660.4	749	806.4	24	1 ³ / ₈	1 ¹ / ₄	10	225	
28	927	69.8	69.8	124	727	711.2	800	863.6	28	1 ³ / ₈	1 ¹ / ₄	11	230	
30	984	73.2	73.2	135	781	762.0	857	914.4	28	1 ³ / ₈	1 ¹ / ₄	11	235	
32	1060	79.5	79.5	143	832	812.8	914	977.9	28	1 ⁵ / ₈	1 ¹ / ₂	11	265	
34	1111	81.0	81.0	148	883	863.6	965	1028.7	32	1 ⁵ / ₈	1 ¹ / ₂	13	270	
36	1168	88.9	88.9	156	933	914.4	1022	1085.8	32	1 ⁵ / ₈	1 ¹ / ₂	13	285	
38	1238	85.9	85.9	156	991	965.2	1073	1149.4	32	1 ⁵ / ₈	1 ¹ / ₂	13	280	
40	1289	88.9	88.9	162	1041	1016.0	1124	1200.2	36	1 ⁵ / ₈	1 ¹ / ₂	13	285	
42	1346	95.2	95.2	170	1092	1066.8	1194	1257.3	36	1 ⁵ / ₈	1 ¹ / ₂	13	300	
44	1403	100.1	100.1	176	1143	1117.6	1245	1314.4	40	1 ⁵ / ₈	1 ¹ / ₂	13	305	
46	1454	101.6	101.6	184	1197	1168.4	1295	1365.2	40	1 ⁵ / ₈	1 ¹ / ₂	13	310	
48	1511	106.4	106.4	191	1248	1219.2	1359	1422.4	44	1 ⁵ / ₈	1 ¹ / ₂	13	320	
50	1568	109.7	109.7	202	1302	1270.0	1410	1479.6	44	1 ⁷ / ₈	1 ³ / ₄	13	340	
52	1626	114.3	114.3	208	1353	1320.8	1461	1536.7	44	1 ⁷ / ₈	1 ³ / ₄	13	350	
54	1683	119.1	119.1	214	1403	1371.6	1511	1593.8	44	1 ⁷ / ₈	1 ³ / ₄	13	360	
56	1746	122.4	122.4	227	1457	1422.4	1575	1651.0	48	1 ⁷ / ₈	1 ³ / ₄	13	365	
58	1803	127.0	127.0	233	1508	1473.2	1626	1708.2	48	1 ⁷ / ₈	1 ³ / ₄	13	380	
60	1854	130.3	130.3	238	1559	1524.0	1676	1759.0	52	1 ⁷ / ₈	1 ³ / ₄	13	380	

GENERAL NOTES:

- (a) Dimensions are in millimeters unless otherwise noted.
- (b) For tolerances, see section 7.
- (c) For facings, see para. 6.1.
- (d) For flange bolt holes, see para. 6.2.
- (e) For spot facing, see para. 6.3.
- (f) The bore is to be specified by the purchaser. Tolerances in para. 7.3.2 apply.
- (g) Blind flanges may be made with or without hubs at the manufacturer's option. The manufacturer or purchaser may modify blind flanges with the following features:
 - (1) a hole bored to match the inside diameter of a slip-on flange up to NPS 3
 - (2) a socket equivalent to that provided for a socket-welding flange up to NPS 3
 - (3) an internal thread to ASME B1.20.1 up to NPS 3

Holes can be placed anywhere within the inside diameter of the mating pipe. When multiple holes are provided, they shall be separated by a distance at least equal to that of the diameter of the largest hole being added.

NOTES:

- (1) The minimum flange thickness does not include the raised face thickness (see para. 6.1.1).

Table 31 Dimensions of Class 150 Series A Flanges (Cont'd)

NOTES: (Cont'd)

- (2) This dimension is for the large end of hub, which may be straight or tapered.
- (3) For welding and bevel, see [para. 6.4](#).
- (4) The length of the stud bolt does not include the height of the points (see [para. 6.5.2](#)).
- (5) Bolt lengths not shown in the table may be determined in accordance with [Nonmandatory Appendix D](#) (see [para. 6.5.2](#)).

Table 31C Dimensions of Class 150 Series A Flanges

(20)

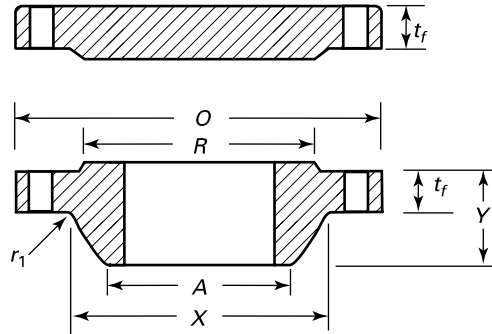

Nominal Pipe Size	O.D. of Flange, O	Minimum Thickness of Flange, t_f [Note (1)]		Length Through Hub, Y	Diam. of Hub, X [Note (2)]	Hub Diam. Top, A [Note (3)]	Raised Face Diam., R	Drilling				Minimum Fillet Radius, r_1	Length of Bolts, L [Notes (4), (5)]
		WNF	Blind					No. of Bolt Holes	Diam. of Bolt Hole	Diam. of Bolt	Raised Face 0.06 in.		
26	34.25	2.63	2.63	4.69	26.62	26.00	29.50	31.75	24	$1\frac{3}{8}$	$1\frac{1}{4}$	0.38	8.75
28	36.50	2.75	2.75	4.88	28.62	28.00	31.50	34.00	28	$1\frac{3}{8}$	$1\frac{1}{4}$	0.44	9.00
30	38.75	2.88	2.88	5.32	30.75	30.00	33.75	36.00	28	$1\frac{3}{8}$	$1\frac{1}{4}$	0.44	9.25
32	41.75	3.13	3.13	5.63	32.75	32.00	36.00	38.50	28	$1\frac{5}{8}$	$1\frac{1}{2}$	0.44	10.50
34	43.75	3.19	3.19	5.82	34.75	34.00	38.00	40.50	32	$1\frac{5}{8}$	$1\frac{1}{2}$	0.50	10.50
36	46.00	3.50	3.50	6.13	36.75	36.00	40.25	42.75	32	$1\frac{5}{8}$	$1\frac{1}{2}$	0.50	11.25
38	48.75	3.38	3.38	6.13	39.00	38.00	42.25	45.25	32	$1\frac{5}{8}$	$1\frac{1}{2}$	0.50	11.00
40	50.75	3.50	3.50	6.38	41.00	40.00	44.25	47.25	36	$1\frac{5}{8}$	$1\frac{1}{2}$	0.50	11.25
42	53.00	3.75	3.75	6.69	43.00	42.00	47.00	49.50	36	$1\frac{5}{8}$	$1\frac{1}{2}$	0.50	11.75
44	55.25	3.94	3.94	6.94	45.00	44.00	49.00	51.75	40	$1\frac{5}{8}$	$1\frac{1}{2}$	0.50	12.00
46	57.25	4.00	4.00	7.25	47.12	46.00	51.00	53.75	40	$1\frac{5}{8}$	$1\frac{1}{2}$	0.50	12.25
48	59.50	4.19	4.19	7.50	49.12	48.00	53.50	56.00	44	$1\frac{5}{8}$	$1\frac{1}{2}$	0.50	12.50
50	61.75	4.32	4.32	7.94	51.25	50.00	55.50	58.25	44	$1\frac{7}{8}$	$1\frac{3}{4}$	0.50	13.50
52	64.00	4.50	4.50	8.19	53.25	52.00	57.50	60.50	44	$1\frac{7}{8}$	$1\frac{3}{4}$	0.50	13.75
54	66.25	4.69	4.69	8.44	55.25	54.00	59.50	62.75	44	$1\frac{7}{8}$	$1\frac{3}{4}$	0.50	14.00
56	68.75	4.82	4.82	8.94	57.38	56.00	62.00	65.00	48	$1\frac{7}{8}$	$1\frac{3}{4}$	0.50	14.50
58	71.00	5.00	5.00	9.19	59.38	58.00	64.00	67.25	48	$1\frac{7}{8}$	$1\frac{3}{4}$	0.50	14.75
60	73.00	5.13	5.13	9.38	61.38	60.00	66.00	69.25	52	$1\frac{7}{8}$	$1\frac{3}{4}$	0.50	15.00

GENERAL NOTES:

- (a) Dimensions are in inches.
- (b) For tolerances, see section 7.
- (c) For facings, see para. 6.1.
- (d) For flange bolt holes, see para. 6.2.
- (e) For spot facing, see para. 6.3.
- (f) The bore is to be specified by the purchaser. Tolerances in para. 7.3.2 apply.
- (g) Blind flanges may be made with or without hubs at the manufacturer's option. The manufacturer or purchaser may modify blind flanges with the following features:
 - (1) a hole bored to match the ID of a slip-on flange up to NPS 3
 - (2) a socket equivalent to that provided for a socket-welding flange up to NPS 3
 - (3) an internal thread to ASME B1.20.1 up to NPS 3

Holes can be placed anywhere within the inside diameter of the mating pipe. When multiple holes are provided, they shall be separated by a distance at least equal to that of the diameter of the largest hole being added.

NOTES:

- (1) The minimum flange thickness does not include the raised face thickness (see para. 6.1.1).

Table 31C Dimensions of Class 150 Series A Flanges (Cont'd)

NOTES: (Cont'd)

- (2) This dimension is for the large end of hub, which may be straight or tapered.
- (3) For welding and bevel, see [para. 6.4](#).
- (4) The length of the stud bolt does not include the height of the points (see [para. 6.5.2](#)).
- (5) Bolt lengths not shown in the table may be determined in accordance with [Nonmandatory Appendix D](#) (see [para. 6.5.2](#)).

Table 32 Dimensions of Class 300 Series A Flanges

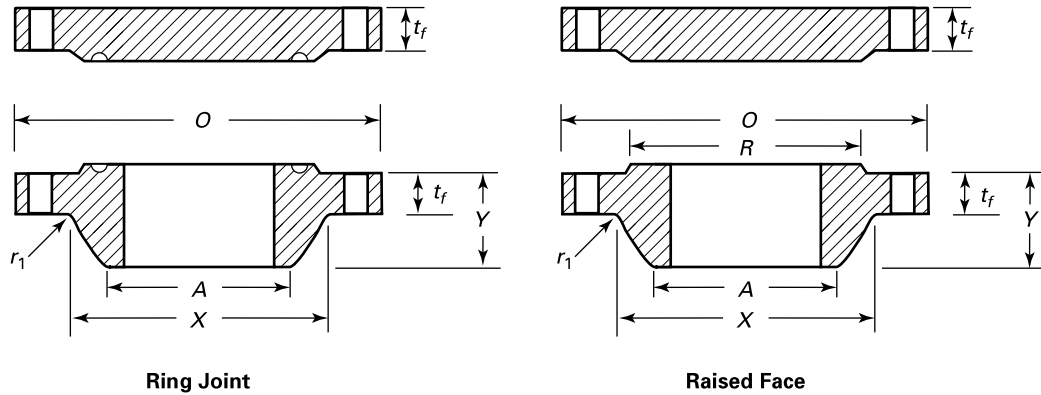

Nominal Pipe Size	O.D. of Flange, O	Minimum Thickness of Flange, t_f [Note (1)]		Length Through Hub, Y	Diam. of Hub, X [Note (2)]	Hub Diam. Top, A [Note (3)]	Raised Face Diam., R	Drilling			Minimum Fillet Radius, r_1	Length of Bolts, L [Notes (4), (5)]		
		WNF	Blind					Diam. of Bolt Hole, in.	Diam. of Bolt, in.	No. of Bolt Holes		Raised Face 1.6 mm	Ring Joint	
26	972	78.0	82.6	183	721	660.4	749	876.3	28	1 ³ / ₄	1 ⁵ / ₈	10	270	290
28	1035	84.3	88.9	195	775	711.2	800	939.8	28	1 ³ / ₄	1 ⁵ / ₈	11	280	300
30	1092	90.7	93.7	208	827	762.0	857	997.0	28	1 ⁷ / ₈	1 ³ / ₄	11	300	320
32	1149	97.0	98.6	221	881	812.8	914	1054.1	28	2	1 ⁷ / ₈	11	320	345
34	1206	100.1	103.4	230	937	863.6	965	1104.9	28	2	1 ⁷ / ₈	13	330	350
36	1270	103.4	109.7	240	991	914.4	1022	1168.4	32	2 ¹ / ₈	2	13	340	365
38	1168	106.4	106.4	179	994	965.2	1029	1092.2	32	1 ⁵ / ₈	1 ¹ / ₂	13	320	...
40	1238	112.8	112.8	192	1048	1016.0	1086	1155.7	32	1 ³ / ₄	1 ⁵ / ₈	13	340	...
42	1289	117.6	117.6	199	1099	1066.8	1137	1206.5	32	1 ³ / ₄	1 ⁵ / ₈	13	350	...
44	1353	122.4	122.4	205	1149	1117.6	1194	1263.6	32	1 ⁷ / ₈	1 ³ / ₄	13	365	...
46	1416	127.0	127.0	214	1203	1168.4	1245	1320.8	28	2	1 ⁷ / ₈	13	380	...
48	1467	131.8	131.8	222	1254	1219.2	1302	1371.6	32	2	1 ⁷ / ₈	13	390	...
50	1530	138.2	138.2	230	1305	1270.0	1359	1428.8	32	2 ¹ / ₈	2	13	410	...
52	1581	143.0	143.0	237	1356	1320.8	1410	1479.6	32	2 ¹ / ₈	2	13	420	...
54	1657	150.9	150.9	251	1410	1371.6	1467	1549.4	28	2 ³ / ₈	2 ¹ / ₄	13	450	...
56	1708	152.4	152.4	259	1464	1422.4	1518	1600.2	28	2 ³ / ₈	2 ¹ / ₄	13	450	...
58	1759	157.2	157.2	265	1514	1473.2	1575	1651.0	32	2 ³ / ₈	2 ¹ / ₄	13	465	...
60	1810	160.1	160.1	272	1565	1524.0	1626	1701.8	32	2 ³ / ₈	2 ¹ / ₄	13	475	...

GENERAL NOTES:

- (a) Dimensions are in millimeters unless otherwise noted.
- (b) For tolerances, see section 7.
- (c) For facings, see para. 6.1.
- (d) For flange bolt holes, see para. 6.2.
- (e) For spot facing, see para. 6.3.
- (f) The bore is to be specified by the purchaser. Tolerances in para. 7.3.2 apply.
- (g) Blind flanges may be made with or without hubs at the manufacturer's option. The manufacturer or purchaser may modify blind flanges with the following features:
 - (1) a hole bored to match the ID of a slip-on flange up to NPS 3
 - (2) a socket equivalent to that provided for a socket-welding flange up to NPS 3
 - (3) an internal thread to ASME B1.20.1 up to NPS 3

Holes can be placed anywhere within the inside diameter of the mating pipe. When multiple holes are provided, they shall be separated by a distance at least equal to that of the diameter of the largest hole being added.

Table 32 Dimensions of Class 300 Series A Flanges (Cont'd)

NOTES:

- (1) The minimum flange thickness does not include the raised face thickness (see [para. 6.1.1](#)).
- (2) This dimension is for the large end of hub, which may be straight or tapered.
- (3) For welding and bevel, see [para. 6.4](#).
- (4) The length of the stud bolt does not include the height of the points (see [para. 6.5.2](#)).
- (5) Bolt lengths not shown in the table may be determined in accordance with [Nonmandatory Appendix D](#) (see [para. 6.5.2](#)).

Table 32C Dimensions of Class 300 Series A Flanges

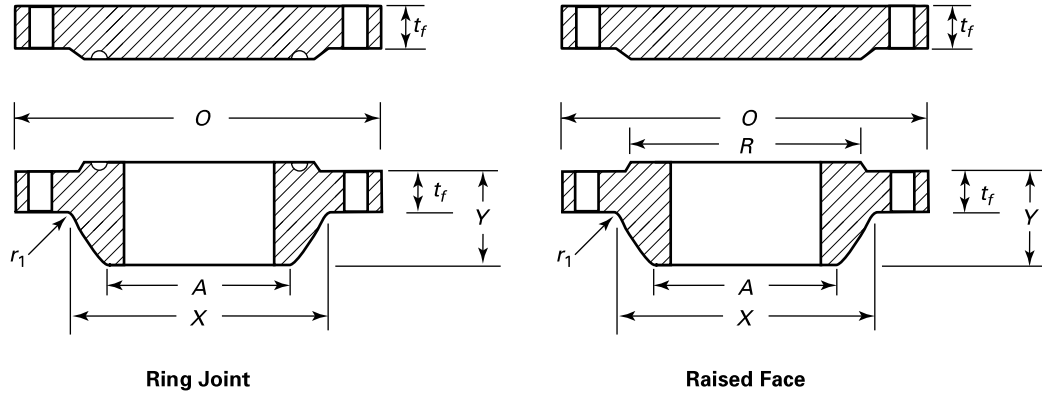

Nominal Pipe Size	O.D. of Flange, <i>O</i>	Minimum Thickness of Flange, <i>t_f</i> [Note (1)]		Length Through Hub, <i>Y</i>	Diam. of Hub, <i>X</i> [Note (2)]	Hub Diam. Top, <i>A</i> [Note (3)]	Raised Face Diam., <i>R</i>	Drilling				Minimum Fillet Radius, <i>r₁</i>	Length of Bolts, <i>L</i> [Notes (4), (5)]	
		WNF	Blind					Diam. of Bolt Circle	No. of Bolt Holes	Diam. of Bolt Hole	Diam. of Bolt		Stud Bolts	
													Raised Face 0.06 in.	Ring Joint
26	38.25	3.07	3.25	7.19	28.38	26.00	29.50	34.50	28	1 ³ / ₄	1 ⁵ / ₈	0.38	10.50	11.50
28	40.75	3.32	3.50	7.69	30.50	28.00	31.50	37.00	28	1 ³ / ₄	1 ⁵ / ₈	0.44	11.00	12.00
30	43.00	3.57	3.69	8.19	32.56	30.00	33.75	39.25	28	1 ⁷ / ₈	1 ³ / ₄	0.44	11.75	12.75
32	45.25	3.82	3.88	8.69	34.69	32.00	36.00	41.50	28	2	1 ⁷ / ₈	0.44	12.75	13.75
34	47.50	3.94	4.07	9.07	36.88	34.00	38.00	43.50	28	2	1 ⁷ / ₈	0.50	13.00	13.75
36	50.00	4.07	4.32	9.44	39.00	36.00	40.25	46.00	32	2 ¹ / ₈	2	0.50	13.50	14.25
38	46.00	4.19	4.19	7.06	39.12	38.00	40.50	43.00	32	1 ⁵ / ₈	1 ¹ / ₂	0.50	12.50	...
40	48.75	4.44	4.44	7.56	41.25	40.00	42.75	45.50	32	1 ³ / ₄	1 ⁵ / ₈	0.50	13.25	...
42	50.75	4.63	4.63	7.82	43.25	42.00	44.75	47.50	32	1 ³ / ₄	1 ⁵ / ₈	0.50	13.75	...
44	53.25	4.82	4.82	8.06	45.25	44.00	47.00	49.75	32	1 ⁷ / ₈	1 ³ / ₄	0.50	14.50	...
46	55.75	5.00	5.00	8.44	47.38	46.00	49.00	52.00	28	2	1 ⁷ / ₈	0.50	15.00	...
48	57.75	5.19	5.19	8.75	49.38	48.00	51.25	54.00	32	2	1 ⁷ / ₈	0.50	15.50	...
50	60.25	5.44	5.44	9.07	51.38	50.00	53.50	56.25	32	2 ¹ / ₈	2	0.50	16.00	...
52	62.25	5.63	5.63	9.32	53.38	52.00	55.50	58.25	32	2 ¹ / ₈	2	0.50	16.50	...
54	65.25	5.94	5.94	9.88	55.50	54.00	57.75	61.00	28	2 ³ / ₈	2 ¹ / ₄	0.50	17.50	...
56	67.25	6.00	6.00	10.19	57.62	56.00	59.75	63.00	28	2 ³ / ₈	2 ¹ / ₄	0.50	17.75	...
58	69.25	6.19	6.19	10.44	59.62	58.00	62.00	65.00	32	2 ³ / ₈	2 ¹ / ₄	0.50	18.25	...
60	71.25	6.38	6.38	10.69	61.62	60.00	64.00	67.00	32	2 ³ / ₈	2 ¹ / ₄	0.50	18.75	...

GENERAL NOTES:

- (a) Dimensions are in inches.
- (b) For tolerances, see section 7.
- (c) For facings, see para. 6.1.
- (d) For flange bolt holes, see para. 6.2.
- (e) For spot facing, see para. 6.3.
- (f) The bore is to be specified by the purchaser. Tolerances in para. 7.3.2 apply.

Table 32C Dimensions of Class 300 Series A Flanges (Cont'd)

GENERAL NOTES: (Cont'd)

(g) Blind flanges may be made with or without hubs at the manufacturer's option. The manufacturer or purchaser may modify blind flanges with the following features:

- (1) a hole bored to match the ID of a slip-on flange up to NPS 3
- (2) a socket equivalent to that provided for a socket-welding flange up to NPS 3
- (3) an internal thread to ASME B1.20.1 up to NPS 3

Holes can be placed anywhere within the inside diameter of the mating pipe. When multiple holes are provided, they shall be separated by a distance at least equal to that of the diameter of the largest hole being added.

NOTES:

- (1) The minimum flange thickness does not include the raised face thickness (see [para. 6.1.1](#)).
- (2) This dimension is for the large end of hub, which may be straight or tapered.
- (3) For welding and bevel, see [para. 6.4](#).
- (4) The length of the stud bolt does not include the height of the points (see [para. 6.5.2](#)).
- (5) Bolt lengths not shown in the table may be determined in accordance with [Nonmandatory Appendix D](#) (see [para. 6.5.2](#)).

Table 33 Dimensions of Class 400 Series A Flanges

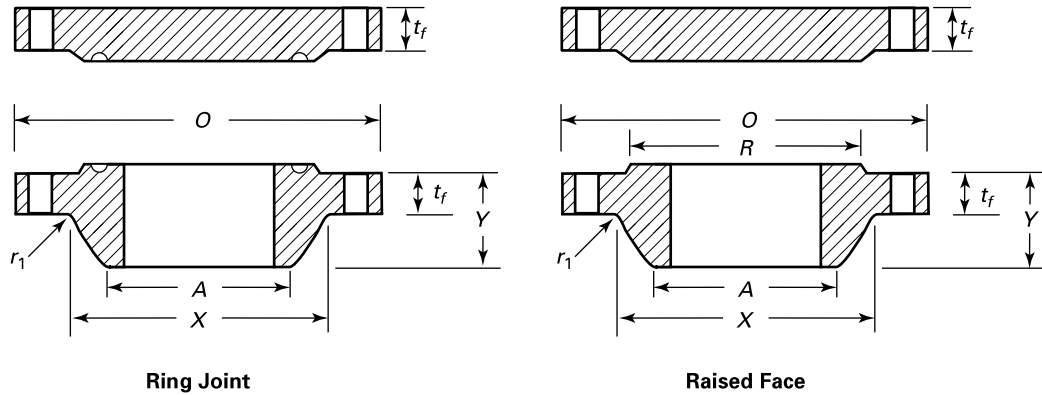

Nominal Pipe Size	O.D. of Flange, O	Minimum Thickness of Flange, t_f [Note (1)]		Length Through Hub, Y	Diam. of Hub, X [Note (2)]	Hub Diam. Top, A [Note (3)]	Raised Face Diam., R	Drilling			Minimum Fillet Radius, r_1	Length of Bolts, L [Notes (4), (5)]		
		WNF	Blind					Diam. of Bolt Hole, in.	No. of Bolt Holes	Diam. of Bolt, in.		Raised Face 6.4 mm	Ring Joint	
26	972	88.9	98.6	194	727	660.4	749	876.3	28	1 ⁷ / ₈	1 ³ / ₄	11	310	320
28	1035	95.2	104.6	206	783	711.2	800	939.8	28	2	1 ⁷ / ₈	13	330	340
30	1092	101.6	111.3	219	837	762.0	857	997.0	28	2 ¹ / ₈	2	13	345	360
32	1149	108.0	115.8	232	889	812.8	914	1054.1	28	2 ¹ / ₈	2	13	360	375
34	1206	111.3	122.2	241	945	863.6	965	1104.9	28	2 ¹ / ₈	2	14	365	380
36	1270	114.3	128.5	251	1000	914.4	1022	1168.4	32	2 ¹ / ₈	2	14	375	385
38	1206	124.0	124.0	206	1003	965.2	1035	1117.6	32	1 ⁷ / ₈	1 ³ / ₄	14	380	...
40	1270	130.0	130.0	216	1054	1016.0	1092	1174.8	32	2	1 ⁷ / ₈	14	405	...
42	1321	133.4	133.4	224	1108	1066.8	1143	1225.6	32	2	1 ⁷ / ₈	14	405	...
44	1384	139.7	139.7	233	1159	1117.6	1200	1282.7	32	2 ¹ / ₈	2	14	425	...
46	1441	146.0	146.0	244	1213	1168.4	1257	1339.8	36	2 ¹ / ₈	2	14	435	...
48	1511	152.4	152.4	257	1267	1219.2	1308	1403.4	28	2 ³ / ₈	2 ¹ / ₄	14	460	...
50	1568	157.2	158.8	268	1321	1270.0	1362	1460.5	32	2 ³ / ₈	2 ¹ / ₄	14	470	...
52	1619	162.1	163.6	276	1372	1320.8	1413	1511.3	32	2 ³ / ₈	2 ¹ / ₄	14	480	...
54	1702	169.9	171.4	289	1425	1371.6	1470	1581.2	28	2 ⁵ / ₈	2 ¹ / ₂	14	510	...
56	1753	174.8	176.3	298	1480	1422.4	1527	1632.0	32	2 ⁵ / ₈	2 ¹ / ₂	14	520	...
58	1803	177.8	180.8	306	1530	1473.2	1578	1682.8	32	2 ⁵ / ₈	2 ¹ / ₂	14	530	...
60	1886	185.7	189.0	319	1584	1524.0	1635	1752.6	32	2 ⁷ / ₈	2 ³ / ₄	14	560	...

GENERAL NOTES:

- (a) Dimensions are in millimeters unless otherwise noted.
- (b) For tolerances, see section 7.
- (c) For facings, see para. 6.1.
- (d) For flange bolt holes, see para. 6.2.
- (e) For spot facing, see para. 6.3.
- (f) The bore is to be specified by the purchaser. Tolerances in para. 7.3.2 apply.
- (g) Blind flanges may be made with or without hubs at the manufacturer's option. The manufacturer or purchaser may modify blind flanges with the following features:
 - (1) a hole bored to match the ID of a slip-on flange up to NPS 3
 - (2) a socket equivalent to that provided for a socket-welding flange up to NPS 3
 - (3) an internal thread to ASME B1.20.1 up to NPS 3

Holes can be placed anywhere within the inside diameter of the mating pipe. When multiple holes are provided, they shall be separated by a distance at least equal to that of the diameter of the largest hole being added.

Table 33 Dimensions of Class 400 Series A Flanges (Cont'd)

NOTES:

- (1) The minimum flange thickness does not include the raised face thickness (see [para. 6.1.1](#)).
- (2) This dimension is for the large end of hub, which may be straight or tapered.
- (3) For welding and bevel, see [para. 6.4](#).
- (4) The length of the stud bolt does not include the height of the points (see [para. 6.5.2](#)).
- (5) Bolt lengths not shown in the table may be determined in accordance with [Nonmandatory Appendix D](#) (see [para. 6.5.2](#)).

Table 33C Dimensions of Class 400 Series A Flanges

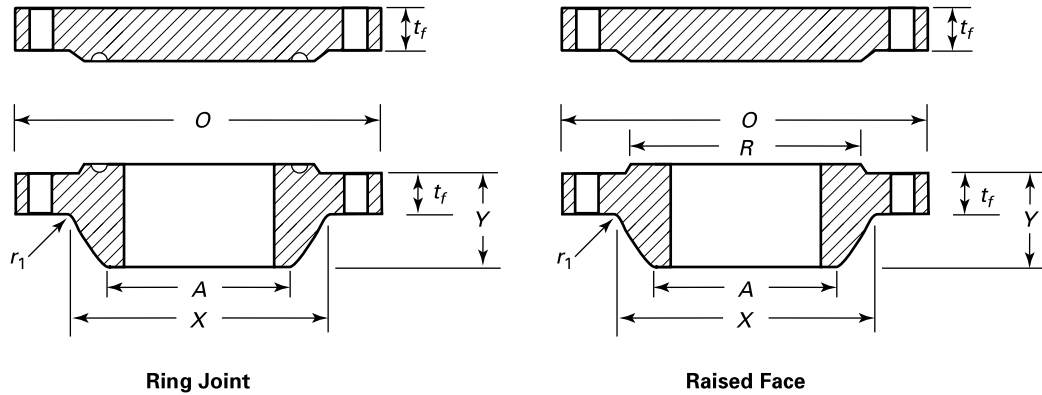

Nominal Pipe Size	O.D. of Flange, O	Minimum Thickness of Flange, t_f [Note (1)]		Length Through Hub, Y	Hub Diam. of Hub, X [Note (2)]	Hub Diam. Top, A [Note (3)]	Raised Face Diam., R	Drilling				Minimum Fillet Radius, r_1	Length of Bolts, L [Notes (4), (5)]	
		WNF	Blind					Diam. of Bolt Circle	No. of Bolt Holes	Diam. of Bolt Hole	Diam. of Bolt		Stud Bolts	
		WNF	Blind										Raised Face 0.25 in.	Ring Joint
26	38.25	3.50	3.88	7.62	28.62	26.00	29.50	34.50	28	1 ⁷ / ₈	1 ³ / ₄	0.44	12.00	12.50
28	40.75	3.75	4.12	8.12	30.81	28.00	31.50	37.00	28	2	1 ⁷ / ₈	0.50	13.00	13.50
30	43.00	4.00	4.38	8.62	32.94	30.00	33.75	39.25	28	2 ¹ / ₈	2	0.50	13.50	14.00
32	45.25	4.25	4.56	9.12	35.00	32.00	36.00	41.50	28	2 ¹ / ₈	2	0.50	14.00	14.75
34	47.50	4.38	4.81	9.50	37.19	34.00	38.00	43.50	28	2 ¹ / ₈	2	0.56	14.50	15.00
36	50.00	4.50	5.06	9.88	39.38	36.00	40.25	46.00	32	2 ¹ / ₈	2	0.56	14.50	15.25
38	47.50	4.88	4.88	8.12	39.50	38.00	40.75	44.00	32	1 ⁷ / ₈	1 ³ / ₄	0.56	15.00	...
40	50.00	5.12	5.12	8.50	41.50	40.00	43.00	46.25	32	2	1 ⁷ / ₈	0.56	15.50	...
42	52.00	5.25	5.25	8.81	43.62	42.00	45.00	48.25	32	2	1 ⁷ / ₈	0.56	16.00	...
44	54.50	5.50	5.50	9.18	45.62	44.00	47.25	50.50	32	2 ¹ / ₈	2	0.56	16.50	...
46	56.75	5.75	5.75	9.62	47.75	46.00	49.50	52.75	36	2 ¹ / ₈	2	0.56	17.00	...
48	59.50	6.00	6.00	10.12	49.88	48.00	51.50	55.25	28	2 ³ / ₈	2 ¹ / ₄	0.56	18.00	...
50	61.75	6.19	6.25	10.56	52.00	50.00	53.62	57.50	32	2 ³ / ₈	2 ¹ / ₄	0.56	18.50	...
52	63.75	6.38	6.44	10.88	54.00	52.00	55.62	59.50	32	2 ³ / ₈	2 ¹ / ₄	0.56	19.00	...
54	67.00	6.69	6.75	11.38	56.12	54.00	57.88	62.25	28	2 ⁵ / ₈	2 ¹ / ₂	0.56	20.00	...
56	69.00	6.88	6.94	11.75	58.25	56.00	60.12	64.25	32	2 ⁵ / ₈	2 ¹ / ₂	0.56	20.50	...
58	71.00	7.00	7.12	12.06	60.25	58.00	62.12	66.25	32	2 ⁵ / ₈	2 ¹ / ₂	0.56	20.75	...
60	74.25	7.31	7.44	12.56	62.38	60.00	64.38	69.00	32	2 ⁷ / ₈	2 ³ / ₄	0.56	21.75	...

GENERAL NOTES:

- (a) Dimensions are in inches.
- (b) For tolerances, see section 7.
- (c) For facings, see para. 6.1.
- (d) For flange bolt holes, see para. 6.2.
- (e) For spot facing, see para. 6.3.
- (f) The bore is to be specified by the purchaser. Tolerances in para. 7.3.2 apply.

Table 33C Dimensions of Class 400 Series A Flanges (Cont'd)

GENERAL NOTES: (Cont'd)

(g) Blind flanges may be made with or without hubs at the manufacturer's option. The manufacturer or purchaser may modify blind flanges with the following features:

- (1) a hole bored to match the ID of a slip-on flange up to NPS 3
- (2) a socket equivalent to that provided for a socket-welding flange up to NPS 3
- (3) an internal thread to ASME B1.20.1 up to NPS 3

Holes can be placed anywhere within the inside diameter of the mating pipe. When multiple holes are provided, they shall be separated by a distance at least equal to that of the diameter of the largest hole being added.

NOTES:

- (1) The minimum flange thickness does not include the raised face thickness (see [para. 6.1.1](#)).
- (2) This dimension is for the large end of hub, which may be straight or tapered.
- (3) For welding and bevel, see [para. 6.4](#).
- (4) The length of the stud bolt does not include the height of the points (see [para. 6.5.2](#)).
- (5) Bolt lengths not shown in the table may be determined in accordance with [Nonmandatory Appendix D](#) (see [para. 6.5.2](#)).

Table 34 Dimensions of Class 600 Series A Flanges

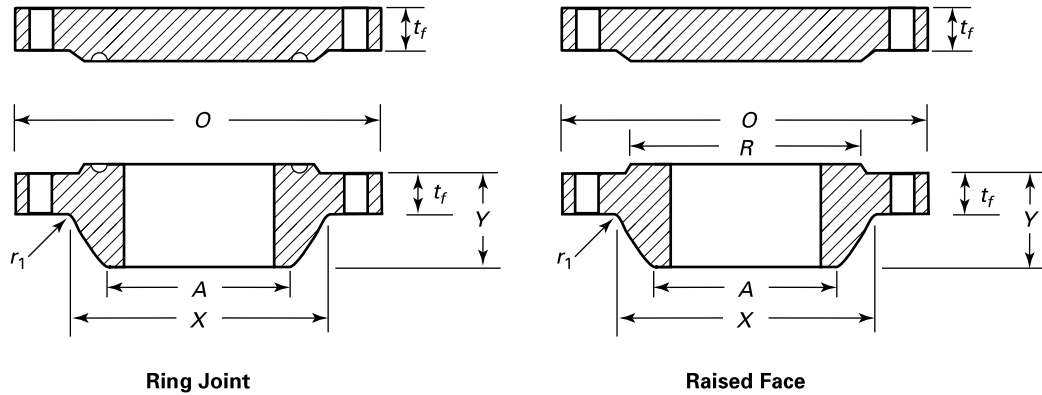

Nominal Pipe Size	O.D. of Flange, O	Minimum Thickness of Flange, t_f [Note (1)]		Length Through Hub, Y	Diam. of Hub, X [Note (2)]	Hub Diam. Top, A [Note (3)]	Raised Face Diam., R	Drilling			Minimum Fillet Radius, r_1	Length of Bolts, L [Notes (4), (5)]		
		WNF	Blind					Diam. of Bolt Hole, in.	No. of Bolt Holes	Diam. of Bolt, in.		Raised Face 6.4 mm	Ring Joint	
26	1016	108.0	125.5	222	748	660.4	749	914.4	28	2	1 ⁷ / ₈	13	355	365
28	1073	111.3	131.8	235	803	711.2	800	965.2	28	2 ¹ / ₈	2	13	365	375
30	1130	114.3	139.7	248	862	762.0	857	1022.4	28	2 ¹ / ₈	2	13	375	385
32	1194	117.3	147.6	260	917	812.8	914	1079.5	28	2 ³ / ₈	2 ¹ / ₄	13	390	405
34	1245	120.6	153.9	270	973	863.6	965	1130.3	28	2 ³ / ₈	2 ¹ / ₄	14	400	410
36	1314	124.0	162.1	282	1032	914.4	1022	1193.8	28	2 ⁵ / ₈	2 ¹ / ₂	14	415	430
38	1270	152.4	155.4	254	1022	965.2	1054	1162.0	28	2 ³ / ₈	2 ¹ / ₄	14	465	...
40	1321	158.8	162.1	264	1073	1016.0	1111	1212.8	32	2 ³ / ₈	2 ¹ / ₄	14	480	...
42	1403	168.1	171.4	279	1127	1066.8	1168	1282.7	28	2 ⁵ / ₈	2 ¹ / ₂	14	510	...
44	1454	173.0	177.8	289	1181	1117.6	1226	1333.5	32	2 ⁵ / ₈	2 ¹ / ₂	14	520	...
46	1511	179.3	185.7	300	1235	1168.4	1276	1390.6	32	2 ⁵ / ₈	2 ¹ / ₂	14	530	...
48	1594	189.0	195.3	316	1289	1219.2	1334	1460.5	32	2 ⁷ / ₈	2 ³ / ₄	14	565	...
50	1670	196.8	203.2	329	1343	1270.0	1384	1524.0	28	3 ¹ / ₈	3	14	595	...
52	1721	203.2	209.6	337	1394	1320.8	1435	1574.8	32	3 ¹ / ₈	3	14	605	...
54	1778	209.6	217.4	349	1448	1371.6	1492	1632.0	32	3 ¹ / ₈	3	14	620	...
56	1854	217.4	225.6	362	1502	1422.4	1543	1695.4	32	3 ³ / ₈	3 ¹ / ₄	16	645	...
58	1905	222.2	231.6	370	1553	1473.2	1600	1746.2	32	3 ³ / ₈	3 ¹ / ₄	16	655	...
60	1994	233.4	242.8	389	1610	1524.0	1657	1822.4	28	3 ⁵ / ₈	3 ¹ / ₂	17	690	...

GENERAL NOTES:

- (a) Dimensions are in millimeters unless otherwise noted.
- (b) For tolerances, see section 7.
- (c) For facings, see para. 6.1.
- (d) For flange bolt holes, see para. 6.2.
- (e) For spot facing, see para. 6.3.
- (f) The bore is to be specified by the purchaser. Tolerances in para. 7.3.2 apply.
- (g) Blind flanges may be made with or without hubs at the manufacturer's option. The manufacturer or purchaser may modify blind flanges with the following features:
 - (1) a hole bored to match the ID of a slip-on flange up to NPS 3
 - (2) a socket equivalent to that provided for a socket-welding flange up to NPS 3
 - (3) an internal thread to ASME B1.20.1 up to NPS 3

Holes can be placed anywhere within the inside diameter of the mating pipe. When multiple holes are provided, they shall be separated by a distance at least equal to that of the diameter of the largest hole being added.

Table 34 Dimensions of Class 600 Series A Flanges (Cont'd)

NOTES:

- (1) The minimum flange thickness does not include the raised face thickness (see [para. 6.1.1](#)).
- (2) This dimension is for the large end of hub, which may be straight or tapered.
- (3) For welding and bevel, see [para. 6.4](#).
- (4) The length of the stud bolt does not include the height of the points (see [para. 6.5.2](#)).
- (5) Bolt lengths not shown in the table may be determined in accordance with [Nonmandatory Appendix D](#) (see [para. 6.5.2](#)).

Table 34C Dimensions of Class 600 Series A Flanges

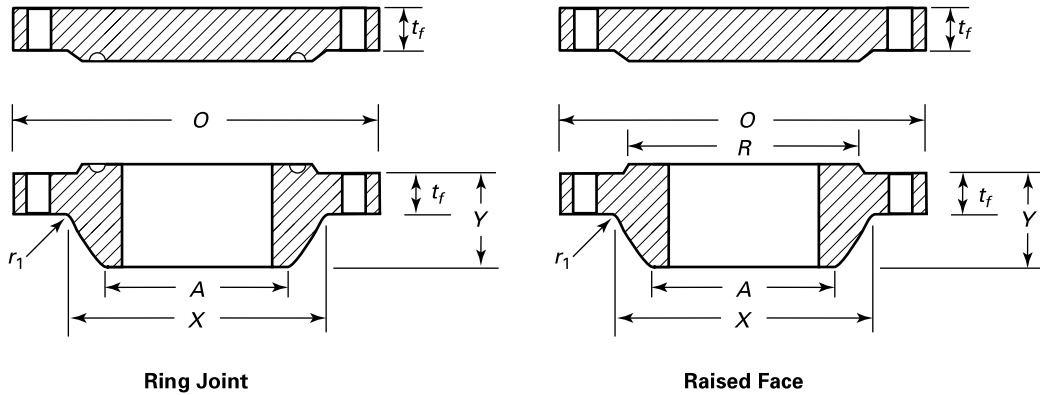

Nominal Pipe Size	O.D. of Flange, O	Minimum Thickness of Flange, t_f [Note (1)]		Length Through Hub, Y	Diam. of Hub, X [Note (2)]	Hub Diam. Top, A [Note (3)]	Raised Face Diam., R	Drilling				Minimum Fillet Radius, r_1	Length of Bolts, L [Notes (4), (5)]	
		WNF	Blind					Diam. of Bolt Circle	No. of Bolt Holes	Diam. of Bolt Hole	Diam. of Bolt		Stud Bolts	
													Raised Face 0.25 in.	Ring Joint
26	40.00	4.25	4.94	8.75	29.44	26.00	29.50	36.00	28	2	1 ⁷ / ₈	0.50	14.00	14.25
28	42.25	4.38	5.19	9.25	31.62	28.00	31.50	38.00	28	2 ¹ / ₈	2	0.50	14.50	15.00
30	44.50	4.50	5.50	9.75	33.94	30.00	33.75	40.25	28	2 ¹ / ₈	2	0.50	14.50	15.00
32	47.00	4.62	5.81	10.25	36.12	32.00	36.00	42.50	28	2 ³ / ₈	2 ¹ / ₄	0.50	15.25	16.00
34	49.00	4.75	6.06	10.62	38.31	34.00	38.00	44.50	28	2 ³ / ₈	2 ¹ / ₄	0.56	15.50	16.25
36	51.75	4.88	6.38	11.12	40.62	36.00	40.25	47.00	28	2 ⁵ / ₈	2 ¹ / ₂	0.56	16.50	17.00
38	50.00	6.00	6.12	10.00	40.25	38.00	41.50	45.75	28	2 ³ / ₈	2 ¹ / ₄	0.56	18.25	...
40	52.00	6.25	6.38	10.38	42.25	40.00	43.75	47.75	32	2 ³ / ₈	2 ¹ / ₄	0.56	18.75	...
42	55.25	6.62	6.75	11.00	44.38	42.00	46.00	50.50	28	2 ⁵ / ₈	2 ¹ / ₂	0.56	20.00	...
44	57.25	6.81	7.00	11.38	46.50	44.00	48.25	52.50	32	2 ⁵ / ₈	2 ¹ / ₂	0.56	20.25	...
46	59.50	7.06	7.31	11.81	48.62	46.00	50.25	54.75	32	2 ⁵ / ₈	2 ¹ / ₂	0.56	20.75	...
48	62.75	7.44	7.69	12.44	50.75	48.00	52.50	57.50	32	2 ⁷ / ₈	2 ³ / ₄	0.56	22.00	...
50	65.75	7.75	8.00	12.94	52.88	50.00	54.50	60.00	28	3 ¹ / ₈	3	0.56	23.25	...
52	67.75	8.00	8.25	13.25	54.88	52.00	56.50	62.00	32	3 ¹ / ₈	3	0.56	23.75	...
54	70.00	8.25	8.56	13.75	57.00	54.00	58.75	64.25	32	3 ¹ / ₈	3	0.56	24.25	...
56	73.00	8.56	8.88	14.25	59.12	56.00	60.75	66.75	32	3 ³ / ₈	3 ¹ / ₄	0.62	25.50	...
58	75.00	8.75	9.12	14.56	61.12	58.00	63.00	68.75	32	3 ³ / ₈	3 ¹ / ₄	0.62	25.75	...
60	78.50	9.19	9.56	15.31	63.38	60.00	65.25	71.75	28	3 ⁵ / ₈	3 ¹ / ₂	0.69	27.25	...

GENERAL NOTES:

- (a) Dimensions are in inches.
- (b) For tolerances, see section 7.
- (c) For facings, see para. 6.1.
- (d) For flange bolt holes, see para. 6.2.
- (e) For spot facing, see para. 6.3.
- (f) The bore is to be specified by the purchaser. Tolerances in para. 7.3.2 apply.

Table 34C Dimensions of Class 600 Series A Flanges (Cont'd)

GENERAL NOTES: (Cont'd)

(g) Blind flanges may be made with or without hubs at the manufacturer's option. The manufacturer or purchaser may modify blind flanges with the following features:

- (1) a hole bored to match the ID of a slip-on flange up to NPS 3
- (2) a socket equivalent to that provided for a socket-welding flange up to NPS 3
- (3) an internal thread to ASME B1.20.1 up to NPS 3

Holes can be placed anywhere within the inside diameter of the mating pipe. When multiple holes are provided, they shall be separated by a distance at least equal to that of the diameter of the largest hole being added.

NOTES:

- (1) The minimum flange thickness does not include the raised face thickness (see [para. 6.1.1](#)).
- (2) This dimension is for the large end of hub, which may be straight or tapered.
- (3) For welding and bevel, see [para. 6.4](#).
- (4) The length of the stud bolt does not include the height of the points (see [para. 6.5.2](#)).
- (5) Bolt lengths not shown in the table may be determined in accordance with [Nonmandatory Appendix D](#) (see [para. 6.5.2](#)).

Table 35 Dimensions of Class 900 Series A Flanges

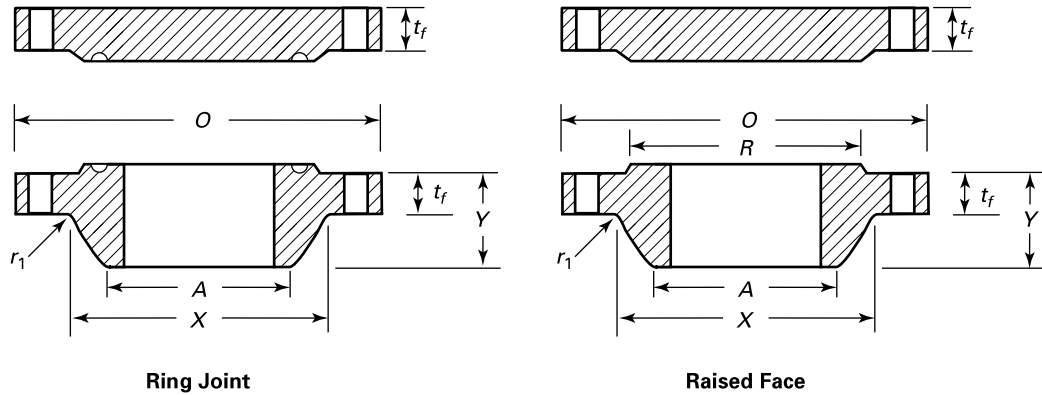

Nominal Pipe Size	O.D. of Flange, O	Minimum Thickness of Flange, t_f [Note (1)]		Length Through Hub, Y	Diam. of Hub, X [Note (2)]	Hub Diam. Top, A [Note (3)]	Raised Face Diam., R	Drilling			Minimum Fillet Radius, r_1	Length of Bolts, L [Notes (4), (5)]		
		WNF	Blind					Diam. of Bolt Hole, in.	Diam. of Bolt, in.	No. of Bolt Holes		Raised Face 6.4 mm	Ring Joint	
26	1086	139.7	160.3	286	775	660.4	749	952.5	20	2 ⁷ / ₈	2 ³ / ₄	11	465	485
28	1168	142.7	171.4	298	832	711.2	800	1022.4	20	3 ¹ / ₈	3	13	485	505
30	1232	129.4	182.4	311	889	762.0	857	1085.8	20	3 ¹ / ₈	3	13	495	520
32	1314	158.8	193.5	330	946	812.8	914	1155.7	20	3 ³ / ₈	3 ¹ / ₄	13	530	550
34	1397	165.1	204.7	349	1006	863.6	965	1225.6	20	3 ⁵ / ₈	3 ¹ / ₂	14	555	580
36	1460	171.4	214.4	362	1064	914.4	1022	1289.0	20	3 ⁵ / ₈	3 ¹ / ₂	14	565	595
38	1460	190.5	215.9	353	1073	965.2	1099	1289.0	20	3 ⁵ / ₈	3 ¹ / ₂	19	605	...
40	1511	196.8	223.8	363	1127	1016.0	1162	1339.8	24	3 ⁵ / ₈	3 ¹ / ₂	21	620	...
42	1562	206.2	231.6	371	1176	1066.8	1213	1390.6	24	3 ⁵ / ₈	3 ¹ / ₂	21	635	...
44	1648	214.4	242.8	391	1235	1117.6	1270	1463.5	24	3 ⁷ / ₈	3 ³ / ₄	22	665	...
46	1734	225.6	255.5	411	1292	1168.4	1334	1536.7	24	4 ¹ / ₈	4	22	700	...
48	1784	233.4	263.7	419	1343	1219.2	1384	1587.5	24	4 ¹ / ₈	4	24	715	...
50
52
54
56
58
60

GENERAL NOTES:

- (a) Dimensions are in millimeters unless otherwise noted.
- (b) For tolerances, see section 7.
- (c) For facings, see para. 6.1.
- (d) For flange bolt holes, see para. 6.2.
- (e) For spot facing, see para. 6.3.
- (f) The bore is to be specified by the purchaser. Tolerances in para. 7.3.2 apply.
- (g) Blind flanges may be made with or without hubs at the manufacturer's option. The manufacturer or purchaser may modify blind flanges with the following features:
 - (1) a hole bored to match the ID of a slip-on flange up to NPS 3
 - (2) a socket equivalent to that provided for a socket-welding flange up to NPS 3
 - (3) an internal thread to ASME B1.20.1 up to NPS 3

Holes can be placed anywhere within the inside diameter of the mating pipe. When multiple holes are provided, they shall be separated by a distance at least equal to that of the diameter of the largest hole being added.

Table 35 Dimensions of Class 900 Series A Flanges (Cont'd)

NOTES:

- (1) The minimum flange thickness does not include the raised face thickness (see [para. 6.1.1](#)).
- (2) This dimension is for the large end of hub, which may be straight or tapered.
- (3) For welding and bevel, see [para. 6.4](#).
- (4) The length of the stud bolt does not include the height of the points (see [para. 6.5.2](#)).
- (5) Bolt lengths not shown in the table may be determined in accordance with [Nonmandatory Appendix D](#) (see [para. 6.5.2](#)).

Table 35C Dimensions of Class 900 Series A Flanges

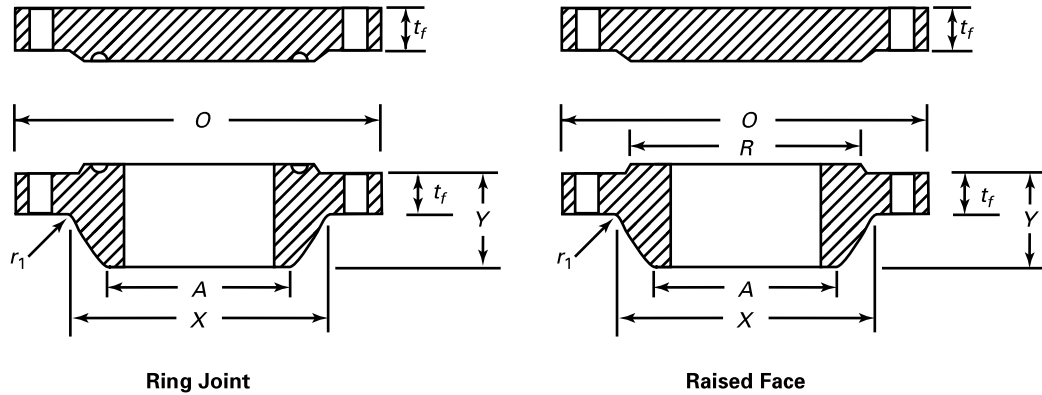

Nominal Pipe Size	O.D. of Flange, O	Minimum Thickness of Flange, t_f [Note (1)]		Length Through Hub, Y	Diam. of Hub, X [Note (2)]	Hub Diam. Top, A [Note (3)]	Raised Face Diam., R	Drilling				Minimum Fillet Radius, r_1	Length of Bolts, L [Notes (4), (5)]	
		WNF	Blind					No. of Bolt Holes	Diam. of Bolt Hole	Diam. of Bolt	Stud Bolts			
		WNF	Blind								Raised Face 0.25 in.		Ring Joint	
26	42.75	5.50	6.31	11.25	30.50	26.00	29.50	37.50	20	2 ⁷ / ₈	2 ³ / ₄	0.44	18.25	19.00
28	46.00	5.62	6.75	11.75	32.75	28.00	31.50	40.25	20	3 ¹ / ₈	3	0.50	19.00	19.75
30	48.50	5.88	7.18	12.25	35.00	30.00	33.75	42.75	20	3 ¹ / ₈	3	0.50	19.50	20.25
32	51.75	6.25	7.62	13.00	37.25	32.00	36.00	45.50	20	3 ³ / ₈	3 ¹ / ₄	0.50	20.75	21.50
34	55.00	6.50	8.06	13.75	39.62	34.00	38.00	48.25	20	3 ⁵ / ₈	3 ¹ / ₂	0.56	21.75	22.75
36	57.50	6.75	8.44	14.25	41.88	36.00	40.25	50.75	20	3 ⁵ / ₈	3 ¹ / ₂	0.56	22.25	23.25
38	57.50	7.50	8.50	13.88	42.25	38.00	43.25	50.75	20	3 ⁵ / ₈	3 ¹ / ₂	0.75	23.75	...
40	59.50	7.75	8.81	14.31	44.38	40.00	45.75	52.75	24	3 ⁵ / ₈	3 ¹ / ₂	0.81	24.50	...
42	61.50	8.12	9.12	14.62	46.31	42.00	47.75	54.75	24	3 ⁵ / ₈	3 ¹ / ₂	0.81	25.00	...
44	64.88	8.44	9.56	15.38	48.62	44.00	50.00	57.62	24	3 ⁷ / ₈	3 ³ / ₄	0.88	26.00	...
46	68.25	8.88	10.06	16.18	50.88	46.00	52.50	60.50	24	4 ¹ / ₈	4	0.88	27.50	...
48	70.25	9.19	10.38	16.50	52.88	48.00	54.50	62.50	24	4 ¹ / ₈	4	0.94	28.00	...
50
52
54
56
58
60

GENERAL NOTES:

- (a) Dimensions are in inches.
- (b) For tolerances, see section 7.
- (c) For facings, see para. 6.1.
- (d) For flange bolt holes, see para. 6.2.
- (e) For spot facing, see para. 6.3.
- (f) The bore is to be specified by the purchaser. Tolerances in para. 7.3.2 apply.

Table 35C Dimensions of Class 900 Series A Flanges (Cont'd)

GENERAL NOTES: (Cont'd)

(g) Blind flanges may be made with or without hubs at the manufacturer's option. The manufacturer or purchaser may modify blind flanges with the following features:

- (1) a hole bored to match the ID of a slip-on flange up to NPS 3
- (2) a socket equivalent to that provided for a socket-welding flange up to NPS 3
- (3) an internal thread to ASME B1.20.1 up to NPS 3

Holes can be placed anywhere within the inside diameter of the mating pipe. When multiple holes are provided, they shall be separated by a distance at least equal to that of the diameter of the largest hole being added.

NOTES:

- (1) The minimum flange thickness does not include the raised face thickness (see [para. 6.1.1](#)).
- (2) This dimension is for the large end of hub, which may be straight or tapered.
- (3) For welding and bevel, see [para. 6.4](#).
- (4) The length of the stud bolt does not include the height of the points (see [para. 6.5.2](#)).
- (5) Bolt lengths not shown in the table may be determined in accordance with [Nonmandatory Appendix D](#) (see [para. 6.5.2](#)).

Table 36 Dimensions of Class 75 Series B Flanges

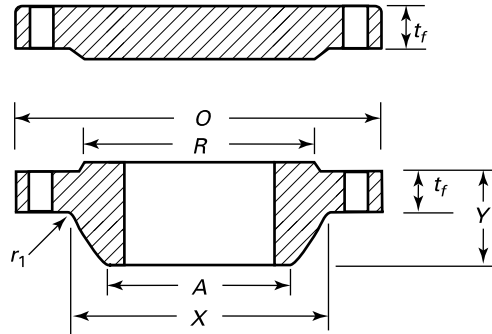

Nominal Pipe Size	O.D. of Flange, O	Minimum Thickness of Flange, t_f [Note (1)]		Length Through Hub, Y	Diam. of Hub, X [Note (2)]	Hub Diam. Top, A [Note (3)]	Raised Face Diam., R	Drilling			Minimum Fillet Radius, r_1	Length of Bolts, L [Notes (4), (5)]	
		WNF	Blind					No. of Bolt Holes	Diam. of Bolt Hole, in.	Diam. of Bolt, in.		Stud Bolts	
												Raised Face 1.6 mm	
26	760	31.8	31.8	57	676	661.9	705	723.9	36	3/4	5/8	8	115
28	813	31.8	31.8	60	727	712.7	756	774.7	40	3/4	5/8	8	115
30	864	31.8	31.8	64	778	763.5	806	825.5	44	3/4	5/8	8	115
32	914	33.5	35.1	68	829	814.3	857	876.3	48	3/4	5/8	8	120
34	965	33.5	36.6	72	879	865.1	908	927.1	52	3/4	5/8	8	120
36	1034	35.1	40.9	84	935	915.9	965	992.1	40	7/8	3/4	10	130
38	1084	36.6	42.9	87	986	966.7	1016	1042.9	40	7/8	3/4	10	130
40	1135	36.6	42.9	91	1037	1017.5	1067	1093.7	44	7/8	3/4	10	130
42	1186	38.1	46.2	94	1087	1068.3	1118	1144.5	48	7/8	3/4	10	135
44	1251	41.4	47.8	103	1140	1119.1	1175	1203.5	36	1	7/8	10	150
46	1302	42.9	49.3	106	1191	1169.9	1226	1254.3	40	1	7/8	10	150
48	1353	44.6	52.6	110	1242	1220.7	1276	1305.1	44	1	7/8	10	160
50	1403	46.2	54.1	114	1294	1271.5	1327	1355.9	44	1	7/8	10	160
52	1457	46.2	55.6	119	1345	1322.3	1378	1409.7	48	1	7/8	10	160
54	1508	47.8	58.9	124	1397	1373.1	1429	1460.5	48	1	7/8	10	160
56	1575	49.3	60.5	133	1451	1423.9	1486	1521.0	40	1 1/8	1	11	170
58	1626	50.8	62.0	137	1502	1474.7	1537	1571.8	44	1 1/8	1	11	180
60	1676	54.1	65.3	143	1553	1525.5	1588	1622.6	44	1 1/8	1	11	185

GENERAL NOTES:

- (a) Dimensions are in millimeters unless otherwise noted.
- (b) For tolerances, see section 7.
- (c) For facings, see para. 6.1.
- (d) For flange bolt holes, see para. 6.2.
- (e) For spot facing, see para. 6.3.
- (f) The bore is to be specified by the purchaser. Tolerances in para. 7.3.2 apply.
- (g) Blind flanges may be made with or without hubs at the manufacturer's option. The manufacturer or purchaser may modify blind flanges with the following features:
 - (1) a hole bored to match the ID of a slip-on flange up to NPS 3
 - (2) a socket equivalent to that provided for a socket-welding flange up to NPS 3
 - (3) an internal thread to ASME B1.20.1 up to NPS 3

Holes can be placed anywhere within the inside diameter of the mating pipe. When multiple holes are provided, they shall be separated by a distance at least equal to that of the diameter of the largest hole being added.

NOTES:

- (1) The minimum flange thickness does not include the raised face thickness (see para. 6.1.1).

Table 36 Dimensions of Class 75 Series B Flanges (Cont'd)

NOTES: (Cont'd)

- (2) This dimension is for the large end of hub, which may be straight or tapered.
- (3) For welding and bevel, see [para. 6.4](#).
- (4) The length of the stud bolt does not include the height of the points (see [para. 6.5.2](#)).
- (5) Bolt lengths not shown in the table may be determined in accordance with [Nonmandatory Appendix D](#) (see [para. 6.5.2](#)).

Table 36C Dimensions of Class 75 Series B Flanges

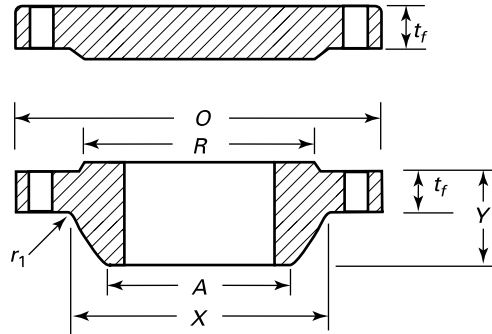

Nominal Pipe Size	O.D. of Flange, O	Minimum Thickness of Flange, t_f [Note (1)]		Length Through Hub, Y	Diam. of Hub, X [Note (2)]	Hub Diam. Top, A [Note (3)]	Raised Face Diam., R	Drilling				Minimum Fillet Radius, r_1	Length of Bolts, L [Notes (4), (5)]
		WNF	Blind					No. of Bolt Holes	Diam. of Bolt Hole	Diam. of Bolt	Raised Face 0.06 in.		
26	30.00	1.25	1.25	2.25	26.62	26.06	27.75	28.50	36	3/4	5/8	0.31	4.50
28	32.00	1.25	1.25	2.38	28.62	28.06	29.75	30.50	40	3/4	5/8	0.31	4.50
30	34.00	1.25	1.25	2.50	30.62	30.06	31.75	32.50	44	3/4	5/8	0.31	4.75
32	36.00	1.32	1.38	2.69	32.62	32.06	33.75	34.50	48	3/4	5/8	0.31	4.75
34	38.00	1.32	1.44	2.82	34.62	34.06	35.75	36.50	52	3/4	5/8	0.31	4.75
36	40.69	1.38	1.61	3.32	36.81	36.06	38.00	39.06	40	7/8	3/4	0.38	5.00
38	42.69	1.44	1.69	3.44	38.81	38.06	40.00	41.06	40	7/8	3/4	0.38	5.25
40	44.69	1.44	1.69	3.57	40.81	40.06	42.00	43.06	44	7/8	3/4	0.38	5.25
42	46.69	1.50	1.82	3.69	42.81	42.06	44.00	45.06	48	7/8	3/4	0.38	5.25
44	49.25	1.63	1.88	4.07	44.88	44.06	46.25	47.38	36	1	7/8	0.38	5.75
46	51.25	1.69	1.94	4.19	46.88	46.06	48.25	49.38	40	1	7/8	0.38	6.00
48	53.25	1.75	2.07	4.32	48.88	48.06	50.25	51.38	44	1	7/8	0.38	6.00
50	55.25	1.82	2.13	4.50	50.94	50.06	52.25	53.38	44	1	7/8	0.38	6.25
52	57.38	1.82	2.19	4.69	52.94	52.06	54.25	55.50	48	1	7/8	0.38	6.25
54	59.38	1.88	2.32	4.88	55.00	54.06	56.25	57.50	48	1	7/8	0.38	6.25
56	62.00	1.94	2.38	5.25	57.12	56.06	58.50	59.88	40	1 1/8	1	0.44	6.75
58	64.00	2.00	2.44	5.38	59.12	58.06	60.50	61.88	44	1 1/8	1	0.44	7.00
60	66.00	2.13	2.57	5.63	61.12	60.06	62.50	63.88	44	1 1/8	1	0.44	7.25

GENERAL NOTES:

- (a) Dimensions are in inches.
- (b) For tolerances, see section 7.
- (c) For facings, see para. 6.1.
- (d) For flange bolt holes, see para. 6.2.
- (e) For spot facing, see para. 6.3.
- (f) The bore is to be specified by the purchaser. Tolerances in para. 7.3.2 apply.
- (g) Blind flanges may be made with or without hubs at the manufacturer's option. The manufacturer or purchaser may modify blind flanges with the following features:
 - (1) a hole bored to match the ID of a slip-on flange up to NPS 3
 - (2) a socket equivalent to that provided for a socket-welding flange up to NPS 3
 - (3) an internal thread to ASME B1.20.1 up to NPS 3

Holes can be placed anywhere within the inside diameter of the mating pipe. When multiple holes are provided, they shall be separated by a distance at least equal to that of the diameter of the largest hole being added.

NOTES:

- (1) The minimum flange thickness does not include the raised face thickness (see para. 6.1.1).

Table 36C Dimensions of Class 75 Series B Flanges (Cont'd)

NOTES: (Cont'd)

- (2) This dimension is for the large end of hub, which may be straight or tapered.
- (3) For welding and bevel, see [para. 6.4](#).
- (4) The length of the stud bolt does not include the height of the points (see [para. 6.5.2](#)).
- (5) Bolt lengths not shown in the table may be determined in accordance with [Nonmandatory Appendix D](#) (see [para. 6.5.2](#)).

Table 37 Dimensions of Class 150 Series B Flanges

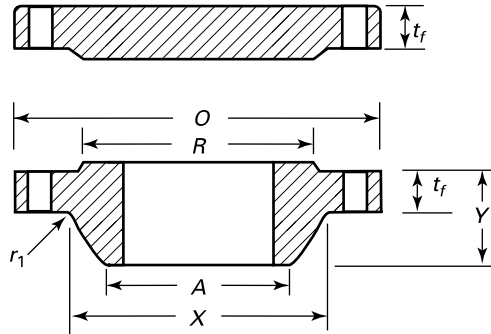

Nominal Pipe Size	O.D. of Flange, O	Minimum Thickness of Flange, t_f [Note (1)]		Length Through Hub, Y	Diam. of Hub, X [Note (2)]	Hub Diam. Top, A [Note (3)]	Raised Face Diam., R	Drilling			Minimum Fillet Radius, r_1	Length of Bolts, L [Notes (4), (5)]	
		WNF	Blind					Diam. of Bolt Circle	No. of Bolt Holes	Diam. of Bolt Hole, in.		Diam. of Bolt, in.	Stud Bolts Raised Face 1.6 mm
26	786	39.9	42.9	87	684	661.9	711	744.5	36	7/8	3/4	10	140
28	837	42.9	46.2	94	735	712.7	762	795.3	40	7/8	3/4	10	145
30	887	42.9	49.3	98	787	763.5	813	846.1	44	7/8	3/4	10	145
32	941	44.4	52.6	106	840	814.3	864	900.2	48	7/8	3/4	10	150
34	1005	47.8	55.6	109	892	865.1	921	957.3	40	1	7/8	10	165
36	1057	50.8	57.2	116	945	915.9	972	1009.6	44	1	7/8	10	165
38	1124	52.6	62.0	122	997	968.2	1022	1069.8	40	1 1/8	1	10	185
40	1175	54.1	65.3	127	1049	1019.0	1080	1120.6	44	1 1/8	1	10	185
42	1226	57.2	66.8	132	1102	1069.8	1130	1171.4	48	1 1/8	1	11	190
44	1276	58.9	69.8	135	1153	1120.6	1181	1222.2	52	1 1/8	1	11	195
46	1341	60.5	73.2	143	1205	1171.4	1235	1284.2	40	1 1/4	1 1/8	11	205
48	1392	63.5	76.2	148	1257	1222.2	1289	1335.0	44	1 1/4	1 1/8	11	210
50	1443	66.8	79.5	152	1308	1273.0	1340	1385.8	48	1 1/4	1 1/8	11	215
52	1494	68.3	82.6	156	1360	1323.8	1391	1436.6	52	1 1/4	1 1/8	11	220
54	1549	69.8	85.9	161	1413	1374.6	1441	1492.2	56	1 1/4	1 1/8	11	225
56	1600	71.6	88.9	165	1465	1425.4	1492	1543.0	60	1 1/4	1 1/8	14	225
58	1675	73.2	91.9	173	1516	1476.2	1543	1611.4	48	1 3/8	1 1/4	14	235
60	1726	74.7	95.2	178	1570	1527.0	1600	1662.2	52	1 3/8	1 1/4	14	240

GENERAL NOTES:

- (a) Dimensions are in millimeters unless otherwise noted.
- (b) For tolerances, see section 7.
- (c) For facings, see para. 6.1.
- (d) For flange bolt holes, see para. 6.2.
- (e) For spot facing, see para. 6.3.
- (f) The bore is to be specified by the purchaser. Tolerances in para. 7.3.2 apply.
- (g) Blind flanges may be made with or without hubs at the manufacturer's option. The manufacturer or purchaser may modify blind flanges with the following features:
 - (1) a hole bored to match the ID of a slip-on flange up to NPS 3
 - (2) a socket equivalent to that provided for a socket-welding flange up to NPS 3
 - (3) an internal thread to ASME B1.20.1 up to NPS 3

Holes can be placed anywhere within the inside diameter of the mating pipe. When multiple holes are provided, they shall be separated by a distance at least equal to that of the diameter of the largest hole being added.

NOTES:

- (1) The minimum flange thickness does not include the raised face thickness (see para. 6.1.1).

Table 37 Dimensions of Class 150 Series B Flanges (Cont'd)

NOTES: (Cont'd)

- (2) This dimension is for the large end of hub, which may be straight or tapered.
- (3) For welding and bevel, see [para. 6.4](#).
- (4) The length of the stud bolt does not include the height of the points (see [para. 6.5.2](#)).
- (5) Bolt lengths not shown in the table may be determined in accordance with [Nonmandatory Appendix D](#) (see [para. 6.5.2](#)).

Table 37C Dimensions of Class 150 Series B Flanges

(20)

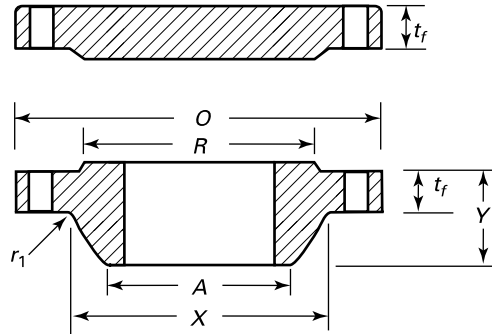

Nominal Pipe Size	O.D. of Flange, O	Minimum Thickness of Flange, t_f [Note (1)]		Length Through Hub, Y	Diam. of Hub, X [Note (2)]	Hub Diam. Top, A [Note (3)]	Raised Face Diam., R	Drilling				Minimum Fillet Radius, r_1	Length of Bolts, L [Notes (4), (5)]
		WNF	Blind					Diam. of Bolt Circle	No. of Bolt Holes	Diam. of Bolt Hole	Diam. of Bolt		
26	30.94	1.57	1.69	3.44	26.94	26.06	28.00	29.31	36	$\frac{7}{8}$	$\frac{3}{4}$	0.38	5.50
28	32.94	1.69	1.82	3.69	28.94	28.06	30.00	31.31	40	$\frac{7}{8}$	$\frac{3}{4}$	0.38	5.75
30	34.94	1.69	1.94	3.88	31.00	30.06	32.00	33.31	44	$\frac{7}{8}$	$\frac{3}{4}$	0.38	5.75
32	37.06	1.75	2.07	4.19	33.06	32.06	34.00	35.44	48	$\frac{7}{8}$	$\frac{3}{4}$	0.38	5.75
34	39.56	1.88	2.19	4.28	35.12	34.06	36.25	37.69	40	1	$\frac{7}{8}$	0.38	6.25
36	41.62	2.00	2.25	4.57	37.19	36.06	38.25	39.75	44	1	$\frac{7}{8}$	0.38	6.50
38	44.25	2.07	2.44	4.82	39.25	38.12	40.25	42.12	40	$1\frac{1}{8}$	1	0.38	7.25
40	46.25	2.13	2.57	5.00	41.31	40.12	42.50	44.12	44	$1\frac{1}{8}$	1	0.38	7.25
42	48.25	2.25	2.63	5.19	43.38	42.12	44.50	46.12	48	$1\frac{1}{8}$	1	0.44	7.50
44	50.25	2.32	2.75	5.32	45.38	44.12	46.50	48.12	52	$1\frac{1}{8}$	1	0.44	7.75
46	52.81	2.38	2.88	5.63	47.44	46.12	48.62	50.56	40	$1\frac{1}{4}$	$1\frac{1}{8}$	0.44	8.00
48	54.81	2.50	3.00	5.82	49.50	48.12	50.75	52.56	44	$1\frac{1}{4}$	$1\frac{1}{8}$	0.44	8.25
50	56.81	2.63	3.13	6.00	51.50	50.12	52.75	54.56	48	$1\frac{1}{4}$	$1\frac{1}{8}$	0.44	8.50
52	58.81	2.69	3.25	6.13	53.56	52.12	54.75	56.56	52	$1\frac{1}{4}$	$1\frac{1}{8}$	0.44	8.75
54	61.00	2.75	3.38	6.32	55.62	54.12	56.75	58.75	56	$1\frac{1}{4}$	$1\frac{1}{8}$	0.44	8.75
56	63.00	2.82	3.50	6.50	57.69	56.12	58.75	60.75	60	$1\frac{1}{4}$	$1\frac{1}{8}$	0.56	9.00
58	65.94	2.88	3.62	6.82	59.69	58.12	60.75	63.44	48	$1\frac{3}{8}$	$1\frac{1}{4}$	0.56	9.25
60	67.94	2.94	3.75	7.00	61.81	60.12	63.00	65.44	52	$1\frac{3}{8}$	$1\frac{1}{4}$	0.56	9.50

GENERAL NOTES:

- (a) Dimensions are in inches.
- (b) For tolerances, see section 7.
- (c) For facings, see para. 6.1.
- (d) For flange bolt holes, see para. 6.2.
- (e) For spot facing, see para. 6.3.
- (f) The bore is to be specified by the purchaser. Tolerances in para. 7.3.2 apply.
- (g) Blind flanges may be made with or without hubs at the manufacturer's option. The manufacturer or purchaser may modify blind flanges with the following features:
 - (1) a hole bored to match the ID of a slip-on flange up to NPS 3
 - (2) a socket equivalent to that provided for a socket-welding flange up to NPS 3
 - (3) an internal thread to ASME B1.20.1 up to NPS 3

Holes can be placed anywhere within the inside diameter of the mating pipe. When multiple holes are provided, they shall be separated by a distance at least equal to that of the diameter of the largest hole being added.

NOTES:

- (1) The minimum flange thickness does not include the raised face thickness (see para. 6.1.1).

Table 37C Dimensions of Class 150 Series B Flanges (Cont'd)

NOTES: (Cont'd)

- (2) This dimension is for the large end of hub, which may be straight or tapered.
- (3) For welding and bevel, see [para. 6.4](#).
- (4) The length of the stud bolt does not include the height of the points (see [para. 6.5.2](#)).
- (5) Bolt lengths not shown in the table may be determined in accordance with [Nonmandatory Appendix D](#) (see [para. 6.5.2](#)).

Table 38 Dimensions of Class 300 Series B Flanges

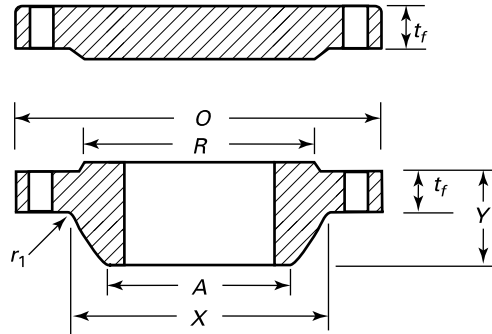

Nominal Pipe Size	O.D. of Flange, O	Minimum Thickness of Flange, t_f [Note (1)]		Length Through Hub, Y	Diam. of Hub, X [Note (2)]	Hub Diam. Top, A [Note (3)]	Raised Face Diam., R	Drilling			Minimum Fillet Radius, r_1	Length of Bolts, L [Notes (4), (5)]	
		WNF	Blind					Diam. of Bolt Circle	No. of Bolt Holes	Diam. of Bolt Hole, in.			Diam. of Bolt, in.
26	867	87.4	87.4	143	702	665.2	737	803.1	32	1 ³ / ₈	1 ¹ / ₄	14	270
28	921	87.4	87.4	148	756	716.0	787	857.2	36	1 ³ / ₈	1 ¹ / ₄	14	270
30	991	92.2	92.2	156	813	768.4	845	920.8	36	1 ¹ / ₂	1 ³ / ₈	14	285
32	1054	101.6	101.6	167	864	819.2	902	977.9	32	1 ⁵ / ₈	1 ¹ / ₂	16	310
34	1108	101.6	101.6	171	917	870.0	952	1031.7	36	1 ⁵ / ₈	1 ¹ / ₂	16	310
36	1171	101.6	101.6	179	965	920.8	1010	1089.2	32	1 ³ / ₄	1 ⁵ / ₈	16	320
38	1222	109.5	109.5	190	1016	971.6	1060	1140.0	36	1 ³ / ₄	1 ⁵ / ₈	16	335
40	1273	114.3	114.3	197	1067	1022.4	1115	1190.8	40	1 ³ / ₄	1 ⁵ / ₈	16	345
42	1334	117.6	117.6	203	1118	1074.7	1168	1244.6	36	1 ⁷ / ₈	1 ³ / ₄	16	355
44	1384	125.5	125.5	213	1173	1125.5	1219	1295.4	40	1 ⁷ / ₈	1 ³ / ₄	16	370
46	1460	127.0	128.5	221	1229	1176.3	1270	1365.2	36	2	1 ⁷ / ₈	16	380
48	1511	127.0	133.4	222	1278	1227.1	1327	1416.0	40	2	1 ⁷ / ₈	16	380
50	1562	136.7	138.2	233	1330	1277.9	1378	1466.8	44	2	1 ⁷ / ₈	16	400
52	1613	141.2	142.5	241	1383	1328.7	1429	1517.6	48	2	1 ⁷ / ₈	16	410
54	1673	135.1	147.6	238	1435	1379.5	1480	1577.8	48	2	1 ⁷ / ₈	16	400
56	1765	152.4	155.4	267	1494	1430.3	1537	1651.0	36	2 ³ / ₈	2 ¹ / ₄	17	450
58	1827	152.4	160.3	273	1548	1481.1	1594	1713.0	40	2 ³ / ₈	2 ¹ / ₄	17	450
60	1878	149.4	165.1	270	1599	1531.9	1651	1763.8	40	2 ³ / ₈	2 ¹ / ₄	17	450

GENERAL NOTES:

- (a) Dimensions are in millimeters unless otherwise noted.
- (b) For tolerances, see section 7.
- (c) For facings, see para. 6.1.
- (d) For flange bolt holes, see para. 6.2.
- (e) For spot facing, see para. 6.3.
- (f) The bore is to be specified by the purchaser. Tolerances in para. 7.3.2 apply.
- (g) Blind flanges may be made with or without hubs at the manufacturer's option. The manufacturer or purchaser may modify blind flanges with the following features:
 - (1) a hole bored to match the ID of a slip-on flange up to NPS 3
 - (2) a socket equivalent to that provided for a socket-welding flange up to NPS 3
 - (3) an internal thread to ASME B1.20.1 up to NPS 3

Holes can be placed anywhere within the inside diameter of the mating pipe. When multiple holes are provided, they shall be separated by a distance at least equal to that of the diameter of the largest hole being added.

NOTES:

- (1) The minimum flange thickness does not include the raised face thickness (see para. 6.1.1).

Table 38 Dimensions of Class 300 Series B Flanges (Cont'd)

NOTES: (Cont'd)

- (2) This dimension is for the large end of hub, which may be straight or tapered.
- (3) For welding and bevel, see [para. 6.4](#).
- (4) The length of the stud bolt does not include the height of the points (see [para. 6.5.2](#)).
- (5) Bolt lengths not shown in the table may be determined in accordance with [Nonmandatory Appendix D](#) (see [para. 6.5.2](#)).

Table 38C Dimensions of Class 300 Series B Flanges

(20)

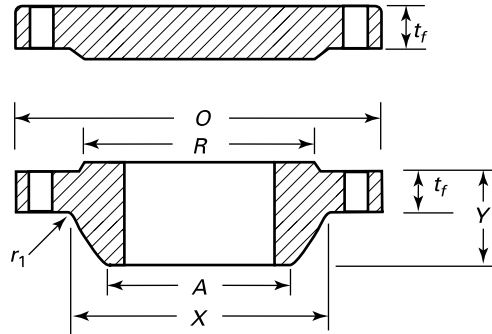

Nominal Pipe Size	O.D. of Flange, O	Minimum Thickness of Flange, t_f [Note (1)]		Length Through Hub, Y	Diam. of Hub, X [Note (2)]	Hub Diam. Top, A [Note (3)]	Raised Face Diam., R	Drilling				Minimum Fillet Radius, r_1	Length of Bolts, L [Notes (4), (5)]
		WNF	Blind					Diam. of Bolt Circle	No. of Bolt Holes	Diam. of Bolt Hole	Diam. of Bolt		
26	34.12	3.44	3.44	5.63	27.62	26.19	29.00	31.62	32	1 ³ / ₈	1 ¹ / ₄	0.56	10.50
28	36.25	3.44	3.44	5.81	29.75	28.19	31.00	33.75	36	1 ³ / ₈	1 ¹ / ₄	0.56	10.50
30	39.00	3.63	3.63	6.16	32.00	30.25	33.25	36.25	36	1 ¹ / ₂	1 ³ / ₈	0.56	11.25
32	41.50	4.00	4.00	6.56	34.00	32.25	35.50	38.50	32	1 ⁵ / ₈	1 ¹ / ₂	0.62	12.25
34	43.62	4.00	4.00	6.75	36.12	34.25	37.50	40.62	36	1 ⁵ / ₈	1 ¹ / ₂	0.62	12.25
36	46.12	4.00	4.00	7.06	38.00	36.25	39.75	42.88	32	1 ³ / ₄	1 ⁵ / ₈	0.62	12.50
38	48.12	4.31	4.31	7.50	40.00	38.25	41.75	44.88	36	1 ³ / ₄	1 ⁵ / ₈	0.62	13.00
40	50.12	4.50	4.50	7.75	42.00	40.25	43.88	46.88	40	1 ³ / ₄	1 ⁵ / ₈	0.62	13.50
42	52.50	4.63	4.63	8.00	44.00	42.31	46.00	49.00	36	1 ⁷ / ₈	1 ³ / ₄	0.62	14.00
44	54.50	4.94	4.94	8.38	46.19	44.31	48.00	51.00	40	1 ⁷ / ₈	1 ³ / ₄	0.62	14.50
46	57.50	5.00	5.06	8.69	48.38	46.31	50.00	53.75	36	2	1 ⁷ / ₈	0.62	15.00
48	59.50	5.00	5.25	8.75	50.31	48.31	52.25	55.75	40	2	1 ⁷ / ₈	0.62	15.00
50	61.50	5.38	5.44	9.19	52.38	50.31	54.25	57.75	44	2	1 ⁷ / ₈	0.62	15.75
52	63.50	5.56	5.61	9.50	54.44	52.31	56.25	59.75	48	2	1 ⁷ / ₈	0.62	16.00
54	65.88	5.32	5.81	9.38	56.50	54.31	58.25	62.12	48	2	1 ⁷ / ₈	0.62	15.75
56	69.50	6.00	6.12	10.50	58.81	56.31	60.50	65.00	36	2 ³ / ₈	2 ¹ / ₄	0.69	17.75
58	71.94	6.00	6.31	10.75	60.94	58.31	62.75	67.44	40	2 ³ / ₈	2 ¹ / ₄	0.69	17.75
60	73.94	5.88	6.50	10.63	62.94	60.31	65.00	69.44	40	2 ³ / ₈	2 ¹ / ₄	0.69	17.50

GENERAL NOTES:

- (a) Dimensions are in inches.
- (b) For tolerances, see section 7.
- (c) For facings, see para. 6.1.
- (d) For flange bolt holes, see para. 6.2.
- (e) For spot facing, see para. 6.3.
- (f) The bore is to be specified by the purchaser. Tolerances in para. 7.3.2 apply.
- (g) Blind flanges may be made with or without hubs at the manufacturer's option. The manufacturer or purchaser may modify blind flanges with the following features:
 - (1) a hole bored to match the ID of a slip-on flange up to NPS 3
 - (2) a socket equivalent to that provided for a socket-welding flange up to NPS 3
 - (3) an internal thread to ASME B1.20.1 up to NPS 3

Holes can be placed anywhere within the inside diameter of the mating pipe. When multiple holes are provided, they shall be separated by a distance at least equal to that of the diameter of the largest hole being added.

NOTES:

- (1) The minimum flange thickness does not include the raised face thickness (see para. 6.1.1).

Table 38C Dimensions of Class 300 Series B Flanges (Cont'd)

NOTES: (Cont'd)

- (2) This dimension is for the large end of hub, which may be straight or tapered.
- (3) For welding and bevel, see [para. 6.4](#).
- (4) The length of the stud bolt does not include the height of the points (see [para. 6.5.2](#)).
- (5) Bolt lengths not shown in the table may be determined in accordance with [Nonmandatory Appendix D](#) (see [para. 6.5.2](#)).

Table 39 Dimensions of Class 400 Series B Flanges

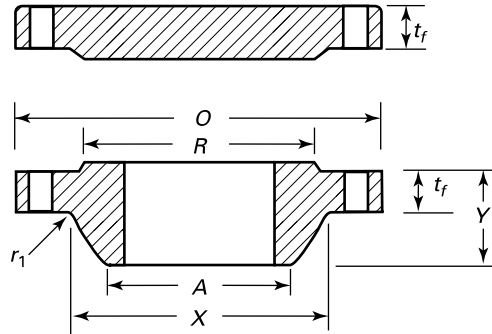

Nominal Pipe Size	O.D. of Flange, O	Minimum Thickness of Flange, t_f [Note (1)]		Length Through Hub, Y	Diam. of Hub, X [Note (2)]	Hub Diam. Top, A [Note (3)]	Raised Face Diam., R	Drilling			Minimum Fillet Radius, r_1	Length of Bolts, L [Notes (4), (5)]	
		WNF	Blind					Diam. of Bolt Circle	No. of Bolt Holes	Diam. of Bolt Hole, in.		Diam. of Bolt, in.	Stud Bolts Raised Face 6.4 mm
26	851	88.9	88.9	149	689	660.4	711	781.0	28	1½	1¾	11	290
28	914	95.2	95.2	159	740	711.2	762	838.2	24	1⅝	1½	13	310
30	972	101.6	101.6	170	794	762.0	819	895.4	28	1⅝	1½	13	320
32	1035	108.0	108.0	179	845	812.8	873	952.5	28	1¾	1⅝	13	345
34	1086	111.3	111.3	187	899	863.6	927	1003.3	32	1¾	1⅝	14	345
36	1156	119.1	119.1	200	952	914.4	981	1066.8	28	1⅞	1¾	14	370
38
40
42
44
46
48
50
52
54
56
58
60

GENERAL NOTES:

- (a) Dimensions are in millimeters unless otherwise noted.
- (b) For tolerances, see section 7.
- (c) For facings, see para. 6.1.
- (d) For flange bolt holes, see para. 6.2.
- (e) For spot facing, see para. 6.3.
- (f) The bore is to be specified by the purchaser. Tolerances in para. 7.3.2 apply.
- (g) Blind flanges may be made with or without hubs at the manufacturer's option. The manufacturer or purchaser may modify blind flanges with the following features:
 - (1) a hole bored to match the ID of a slip-on flange up to NPS 3
 - (2) a socket equivalent to that provided for a socket-welding flange up to NPS 3
 - (3) an internal thread to ASME B1.20.1 up to NPS 3

Holes can be placed anywhere within the inside diameter of the mating pipe. When multiple holes are provided, they shall be separated by a distance at least equal to that of the diameter of the largest hole being added.

- (h) Dimensions for Classes 400, 600, and 900 NPS 38 and larger for Series B flanges are the same as for the Series A flanges.

Table 39 Dimensions of Class 400 Series B Flanges (Cont'd)

NOTES:

- (1) The minimum flange thickness does not include the raised face thickness (see [para. 6.1.1](#)).
- (2) This dimension is for the large end of hub, which may be straight or tapered.
- (3) For welding and bevel, see [para. 6.4](#).
- (4) The length of the stud bolt does not include the height of the points (see [para. 6.5.2](#)).
- (5) Bolt lengths not shown in the table may be determined in accordance with [Nonmandatory Appendix D](#) (see [para. 6.5.2](#)).

Table 39C Dimensions of Class 400 Series B Flanges

(20)

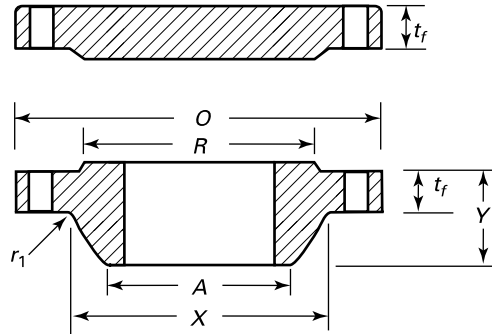

Nominal Pipe Size	O.D. of Flange, O	Minimum Thickness of Flange, t_f [Note (1)]		Length Through Hub, Y	Diam. of Hub, X [Note (2)]	Hub Diam. Top, A [Note (3)]	Raised Face Diam., R	Drilling				Minimum Fillet Radius, r_1	Length of Bolts, L [Notes (4), (5)]
		WNF	Blind					Diam. of Bolt Circle	No. of Bolt Holes	Diam. of Bolt Hole	Diam. of Bolt		
26	33.50	3.50	3.50	5.88	27.12	26.00	28.00	30.75	28	1½	1¾	0.44	14.25
28	36.00	3.75	3.75	6.25	29.12	28.00	30.00	33.00	24	1⅝	1½	0.50	14.75
30	38.25	4.00	4.00	6.69	31.25	30.00	32.25	35.25	28	1⅝	1½	0.50	15.50
32	40.75	4.25	4.25	7.06	33.25	32.00	34.38	37.50	28	1¾	1⅝	0.50	16.25
34	42.75	4.38	4.38	7.38	35.38	34.00	36.50	39.50	32	1¾	1⅝	0.56	17.25
36	45.50	4.69	4.69	7.88	37.50	36.00	38.62	42.00	28	1⅞	1¾	0.56	18.00
38
40
42
44
46
48
50
52
54
56
58
60

GENERAL NOTES:

- (a) Dimensions are in inches.
- (b) For tolerances, see section 7.
- (c) For facings, see para. 6.1.
- (d) For flange bolt holes, see para. 6.2.
- (e) For spot facing, see para. 6.3.
- (f) The bore is to be specified by the purchaser. Tolerances in para. 7.3.2 apply.
- (g) Blind flanges may be made with or without hubs at the manufacturer's option. The manufacturer or purchaser may modify blind flanges with the following features:
 - (1) a hole bored to match the ID of a slip-on flange up to NPS 3
 - (2) a socket equivalent to that provided for a socket-welding flange up to NPS 3
 - (3) an internal thread to ASME B1.20.1 up to NPS 3

Holes can be placed anywhere within the inside diameter of the mating pipe. When multiple holes are provided, they shall be separated by a distance at least equal to that of the diameter of the largest hole being added.

- (h) Dimensions for Classes 400, 600, and 900 NPS 38 and larger for Series B flanges are the same as for the Series A flanges.

Table 39C Dimensions of Class 400 Series B Flanges (Cont'd)

NOTES:

- (1) The minimum flange thickness does not include the raised face thickness (see [para. 6.1.1](#)).
- (2) This dimension is for the large end of hub, which may be straight or tapered.
- (3) For welding and bevel, see [para. 6.4](#).
- (4) The length of the stud bolt does not include the height of the points (see [para. 6.5.2](#)).
- (5) Bolt lengths not shown in the table may be determined in accordance with [Nonmandatory Appendix D](#) (see [para. 6.5.2](#)).

Table 40 Dimensions of Class 600 Series B Flanges

(20)

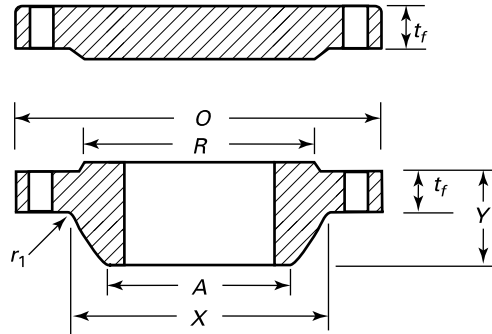

Nominal Pipe Size	O.D. of Flange, O		Length Through Hub, Y	Diam. of Hub, X [Note (2)]	Hub Diam. Top, A [Note (3)]	Raised Face Diam., R	Drilling			Minimum Fillet Radius, r_1	Length of Bolts, L [Notes (4), (5)]		
	WNF	Blind					Diam. of Bolt Circle	No. of Bolt Holes	Diam. of Bolt Hole, in.		Diam. of Bolt, in.	Stud Bolts	Raised Face 6.4 mm
26	889	111.3	111.3	181	698	660.4	727	806.4	28	1 ³ / ₄	1 ⁵ / ₈	13	360
28	952	115.8	115.8	190	752	711.2	784	863.6	28	1 ⁷ / ₈	1 ³ / ₄	13	375
30	1022	125.5	127.0	205	806	762.0	841	927.1	28	2	1 ⁷ / ₈	13	395
32	1086	130.0	134.9	216	861	812.8	895	984.2	28	2 ¹ / ₈	2	13	415
34	1162	141.2	144.3	233	914	863.6	952	1054.1	24	2 ³ / ₈	2 ¹ / ₄	14	440
36	1213	146.0	150.9	243	968	914.4	1010	1104.9	28	2 ³ / ₈	2 ¹ / ₄	14	460
38
40
42
44
46
48
50
52
54
56
58
60

GENERAL NOTES:

- (a) Dimensions are in millimeters unless otherwise noted.
- (b) For tolerances, see section 7.
- (c) For facings, see para. 6.1.
- (d) For flange bolt holes, see para. 6.2.
- (e) For spot facing, see para. 6.3.
- (f) The bore is to be specified by the purchaser. Tolerances in para. 7.3.2 apply.
- (g) Blind flanges may be made with or without hubs at the manufacturer's option. The manufacturer or purchaser may modify blind flanges with the following features:
 - (1) a hole bored to match the ID of a slip-on flange up to NPS 3
 - (2) a socket equivalent to that provided for a socket-welding flange up to NPS 3
 - (3) an internal thread to ASME B1.20.1 up to NPS 3

Holes can be placed anywhere within the inside diameter of the mating pipe. When multiple holes are provided, they shall be separated by a distance at least equal to that of the diameter of the largest hole being added.

- (h) Dimensions for Classes 400, 600, and 900 NPS 38 and larger for Series B flanges are the same as for the Series A flanges.

Table 40 Dimensions of Class 600 Series B Flanges (Cont'd)

NOTES:

- (1) The minimum flange thickness does not include the raised face thickness (see [para. 6.1.1](#)).
- (2) This dimension is for the large end of hub, which may be straight or tapered.
- (3) For welding and bevel, see [para. 6.4](#).
- (4) The length of the stud bolt does not include the height of the points (see [para. 6.5.2](#)).
- (5) Bolt lengths not shown in the table may be determined in accordance with [Nonmandatory Appendix D](#) (see [para. 6.5.2](#)).

Table 40C Dimensions of Class 600 Series B Flanges

(20)

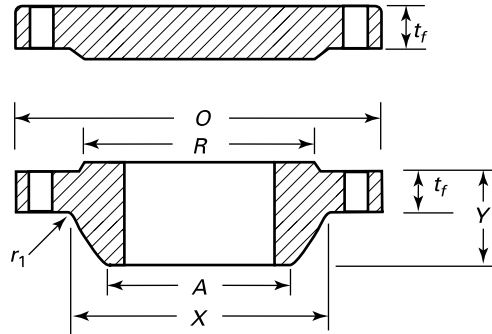

Nominal Pipe Size	O.D. of Flange, O	Minimum Thickness of Flange, t_f [Note (1)]		Length Through Hub, Y	Diam. of Hub, X [Note (2)]	Hub Diam. Top, A [Note (3)]	Raised Face Diam., R	Drilling				Minimum Fillet Radius, r_1	Length of Bolts, L [Notes (4), (5)]
		WNF	Blind					No. of Bolt Holes	Diam. of Bolt Hole	Diam. of Bolt	Raised Face 0.25 in.		
26	35.00	4.38	4.38	7.12	27.50	26.00	28.62	31.75	28	1 ³ / ₄	1 ⁵ / ₈	0.50	14.25
28	37.50	4.56	4.56	7.50	29.62	28.00	30.88	34.00	28	1 ⁷ / ₈	1 ³ / ₄	0.50	14.75
30	40.25	4.94	5.00	8.06	31.75	30.00	33.12	36.50	28	2	1 ⁷ / ₈	0.50	15.50
32	42.75	5.12	5.31	8.50	33.88	32.00	35.25	38.75	28	2 ¹ / ₈	2	0.50	16.25
34	45.75	5.56	5.68	9.19	36.00	34.00	37.50	41.50	24	2 ³ / ₈	2 ¹ / ₄	0.56	17.25
36	47.75	5.75	5.94	9.56	38.12	36.00	39.75	43.50	28	2 ³ / ₈	2 ¹ / ₄	0.56	18.00
38
40
42
44
46
48
50
52
54
56
58
60

GENERAL NOTES:

- (a) Dimensions are in inches.
- (b) For tolerances, see section 7.
- (c) For facings, see para. 6.1.
- (d) For flange bolt holes, see para. 6.2.
- (e) For spot facing, see para. 6.3.
- (f) The bore is to be specified by the purchaser. Tolerances in para. 7.3.2 apply.
- (g) Blind flanges may be made with or without hubs at the manufacturer's option. The manufacturer or purchaser may modify blind flanges with the following features:
 - (1) a hole bored to match the ID of a slip-on flange up to NPS 3
 - (2) a socket equivalent to that provided for a socket-welding flange up to NPS 3
 - (3) an internal thread to ASME B1.20.1 up to NPS 3

Holes can be placed anywhere within the inside diameter of the mating pipe. When multiple holes are provided, they shall be separated by a distance at least equal to that of the diameter of the largest hole being added.

- (h) Dimensions for Classes 400, 600, and 900 NPS 38 and larger for Series B flanges are the same as for the Series A flanges.

Table 40C Dimensions of Class 600 Series B Flanges (Cont'd)

NOTES:

- (1) The minimum flange thickness does not include the raised face thickness (see [para. 6.1.1](#)).
- (2) This dimension is for the large end of hub, which may be straight or tapered.
- (3) For welding and bevel, see [para. 6.4](#).
- (4) The length of the stud bolt does not include the height of the points (see [para. 6.5.2](#)).
- (5) Bolt lengths not shown in the table may be determined in accordance with [Nonmandatory Appendix D](#) (see [para. 6.5.2](#)).

Table 41 Dimensions of Class 900 Series B Flanges

(20)

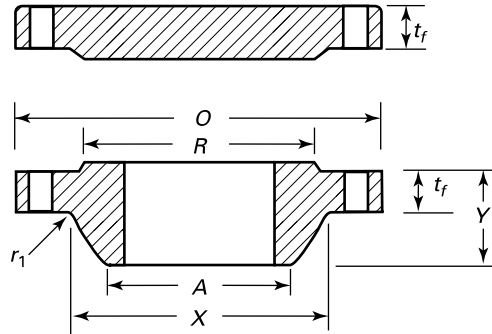

Nominal Pipe Size	O.D. of Flange, O	Minimum Thickness of Flange, t_f [Note (1)]		Length Through Hub, Y	Diam. of Hub, X [Note (2)]	Hub Diam. Top, A [Note (3)]	Raised Face Diam., R	Drilling			Minimum Fillet Radius, r_1	Length of Bolts, L [Notes (4), (5)]		
		WNF	Blind					Diam. of Bolt Circle	No. of Bolt Holes	Diam. of Bolt Hole, in.		Diam. of Bolt, in.	Stud Bolts	
													6.4 mm	Raised Face
26	1022	134.9	153.9	259	743	660.4	762	901.7	20	2 ⁵ / ₈	2 ¹ / ₂	11	450	
28	1105	147.6	166.6	276	797	711.2	819	971.6	20	2 ⁷ / ₈	2 ³ / ₄	13	495	
30	1181	155.4	176.0	289	851	762.0	876	1035.0	20	3 ¹ / ₈	3	13	510	
32	1238	160.3	185.7	303	908	812.8	927	1092.2	20	3 ¹ / ₈	3	13	530	
34	1314	171.4	195.0	319	962	863.6	991	1155.7	20	3 ³ / ₈	3 ¹ / ₄	14	565	
36	1346	173.0	201.7	325	1016	914.4	1029	1200.2	24	3 ¹ / ₈	3	14	570	
38	
40	
42	
44	
46	
48	
50	
52	
54	
56	
58	
60	

GENERAL NOTES:

- (a) Dimensions are in millimeters unless otherwise noted.
- (b) For tolerances, see section 7.
- (c) For facings, see para. 6.1.
- (d) For flange bolt holes, see para. 6.2.
- (e) For sport facing, see para. 6.3.
- (f) The bore is to be specified by the purchaser. Tolerances in para. 7.3.2 apply.
- (g) Blind flanges may be made with or without hubs at the manufacturer's option. The manufacturer or purchaser may modify blind flanges with the following features:
 - (1) a hole bored to match the ID of a slip-on flange up to NPS 3
 - (2) a socket equivalent to that provided for a socket-welding flange up to NPS 3
 - (3) an internal thread to ASME B1.20.1 up to NPS 3

Holes can be placed anywhere within the inside diameter of the mating pipe. When multiple holes are provided, they shall be separated by a distance at least equal to that of the diameter of the largest hole being added.

(h) Dimensions for Classes 400, 600, and 900 NPS 38 and larger for Series B flanges are the same as for the Series A flanges.

Table 41 Dimensions of Class 900 Series B Flanges (Cont'd)

NOTES:

- (1) The minimum flange thickness does not include the raised face thickness (see [para. 6.1.1](#)).
- (2) This dimension is for the large end of hub, which may be straight or tapered.
- (3) For welding and bevel, see [para. 6.4](#).
- (4) The length of the stud bolt does not include the height of the points (see [para. 6.5.2](#)).
- (5) Bolt lengths not shown in the table may be determined in accordance with [Nonmandatory Appendix D](#) (see [para. 6.5.2](#)).

Table 41C Dimensions of Class 900 Series B Flanges

(20)

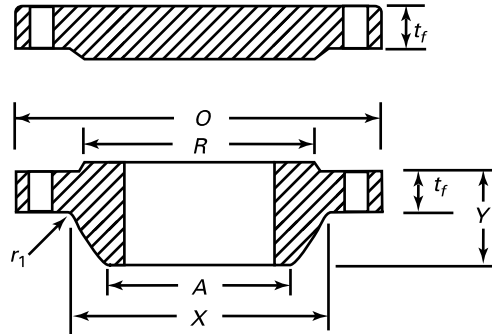

Nominal Pipe Size	O.D. of Flange, O	Minimum Thickness of Flange, t_f [Note (1)]		Length Through Hub, Y	Diam. of Hub, X [Note (2)]	Hub Diam. Top, A [Note (3)]	Raised Face Diam., R	Drilling				Minimum Fillet Radius, r_1	Length of Bolts, L [Notes (4), (5)]
		WNF	Blind					Diam. of Bolt Circle	No. of Bolt Holes	Diam. of Bolt Hole	Diam. of Bolt		
26	40.25	5.31	6.06	10.19	29.25	26.00	30.00	35.50	20	2 ⁵ / ₈	2 ¹ / ₂	0.44	17.75
28	43.50	5.81	6.56	10.88	31.38	28.00	32.25	38.25	20	2 ⁷ / ₈	2 ³ / ₄	0.50	19.25
30	46.50	6.12	6.93	11.38	33.50	30.00	34.50	40.75	20	3 ¹ / ₈	3	0.50	20.00
32	48.75	6.31	7.31	11.94	35.75	32.00	36.50	43.00	20	3 ¹ / ₈	3	0.50	20.75
34	51.75	6.75	7.68	12.56	37.88	34.00	39.00	45.50	20	3 ³ / ₈	3 ¹ / ₄	0.56	22.25
36	53.00	6.81	7.94	12.81	40.00	36.00	40.50	47.25	24	3 ¹ / ₈	3	0.56	22.25
38
40
42
44
46
48
50
52
54
56
58
60

GENERAL NOTES:

- (a) Dimensions are in inches.
- (b) For tolerances, see section 7.
- (c) For facings, see para. 6.1.
- (d) For flange bolt holes, see para. 6.2.
- (e) For spot facing, see para. 6.3.
- (f) The bore is to be specified by the purchaser. Tolerances in para. 7.3.2 apply.
- (g) Blind flanges may be made with or without hubs at the manufacturer's option. The manufacturer or purchaser may modify blind flanges with the following features:
 - (1) a hole bored to match the ID of a slip-on flange up to NPS 3
 - (2) a socket equivalent to that provided for a socket-welding flange up to NPS 3
 - (3) an internal thread to ASME B1.20.1 up to NPS 3

Holes can be placed anywhere within the inside diameter of the mating pipe. When multiple holes are provided, they shall be separated by a distance at least equal to that of the diameter of the largest hole being added.

- (h) Dimensions for Classes 400, 600, and 900 NPS 38 and larger for Series B flanges are the same as for the Series A flanges.

Table 41C Dimensions of Class 900 Series B Flanges (Cont'd)

NOTES:

- (1) The minimum flange thickness does not include the raised face thickness (see [para. 6.1.1](#)).
- (2) This dimension is for the large end of hub, which may be straight or tapered.
- (3) For welding and bevel, see [para. 6.4](#).
- (4) The length of the stud bolt does not include the height of the points (see [para. 6.5.2](#)).
- (5) Bolt lengths not shown in the table may be determined in accordance with [Nonmandatory Appendix D](#) (see [para. 6.5.2](#)).

(20)

Table 42 Flange Bolting Dimensional Recommendations

Product	Carbon Steel	Alloy Steel
Bolts smaller than $\frac{3}{4}$ in.	ASME B18.2.1, square or heavy hex head	ASME B18.2.1, heavy hex head
Bolts equal to or larger than $\frac{3}{4}$ in.	ASME B18.2.1, square or heavy hex head	ASME B18.2.1, heavy hex head
Nuts smaller than $\frac{3}{4}$ in.	ASME B18.2.2, heavy hex	ASME B18.2.2, heavy hex
Nuts equal to or larger than $\frac{3}{4}$ in.	ASME B18.2.2, hex or heavy hex	ASME B18.2.2, heavy hex
Stud bolts	ASME B18.31.2	ASME B18.31.2
External threads	ASME B1.1, Cl. 2A coarse series	ASME B1.1, Cl. 2A coarse series up through 1 in.; eight thread series for larger bolts
Internal threads	ASME B1.1, Cl. 2B coarse series	ASME B1.1, Cl. 2B coarse series up through 1 in.; eight thread series for larger bolts

MANDATORY APPENDIX I REFERENCES

(20)

The following is a list of standards and specifications referenced in this Standard. Products covered by each ASTM specification are listed for convenience. For ASME Codes and Standards listed in this Appendix, the latest edition in effect at the time this edition of this Standard is specified may be used. (See specifications for exact titles and detailed contents.) Materials manufactured to other editions of the referenced ASTM specifications may be used to manufacture fittings meeting the requirements of this Standard as long as the fitting manufacturer verifies that the material meets the requirements of the referenced edition of the ASTM specification.

- ASME B1.1, Unified Inch Screw Threads (UN, UNR, and UNJ Thread Form)
- ASME B1.20.1, Pipe Threads, General Purpose (Inch)
- ASME B16.5, Pipe Flanges and Flanged Fittings: NPS $\frac{1}{2}$ Through NPS 24
- ASME B16.20, Metallic Gaskets for Pipe Flanges
- ASME B16.21, Nonmetallic Flat Gaskets for Pipe Flanges
- ASME B16.34, Valves — Flanged, Threaded, and Welding End
- ASME B18.2.1, Square, Hex, Heavy Hex, and Askew Head Bolts and Hex, Heavy Hex, Hex Flange, Lobed Head, and Lag Screws (Inch Series)
- ASME B18.2.2, Nuts for General Applications: Machine Screw Nuts, Hex, Square, Hex Flange, and Coupling Nuts (Inch Series)
- ASME B18.31.2, Continuous and Double-End Studs (Inch Series)
- ASME B31.3, Process Piping
- ASME B46.1, Surface Texture (Surface Roughness, Waviness, and Lay)
- ASME Boiler and Pressure Vessel Code:
Section I, Rules for Construction of Power Boilers
Section II, Materials
Section III, Rules for Construction of Nuclear Power Plant Components
Section VIII, Divisions 1 & 2, Rules for Construction of Pressure Vessels
- Publisher: The American Society of Mechanical Engineers (ASME), Two Park Avenue, New York, NY 10016-5990 (www.asme.org)
- ASTM A105-2010a, Carbon Steel Forgings for Piping Applications
- ASTM A182-2010a, Forged or Rolled Alloy and Stainless Steel Pipe Flanges, Forged Fittings, and Valves and Parts for High-Temperature Service
- ASTM A193-2010a, Alloy Steel and Stainless Steel Bolting for High-Temperature or High Pressure Service and Other Special Purpose Applications
- ASTM A194-2010a, Carbon and Alloy Steel Nuts for Bolts for High-Pressure or High-Temperature Service, or Both
- ASTM A203-1997(R07), Pressure Vessel Plates, Alloy Steel, Nickel
- ASTM A204-2003(R07), Pressure Vessel Plates, Alloy Steel, Molybdenum
- ASTM A216-2008, Steel Castings, Carbon, Suitable for Fusion Welding, for High-Temperature Service
- ASTM A217-2010, Steel Castings, Martensitic Stainless and Alloy, for Pressure-Containing Parts, Suitable for High-Temperature Service
- ASTM A240-2010b, Chromium and Chromium-Nickel Stainless Steel Plate, Sheet, and Strip for Pressure Vessels and for General Applications
- ASTM A307-2010, Carbon Steel Bolts and Studs, 60,000 psi Tensile Strength
- ASTM A320-2010a, Alloy-Steel and Stainless Steel Bolting for Low-Temperature Service
- ASTM A350-2010, Carbon and Low-Alloy Steel Forgings, Requiring Notch Toughness Testing for Piping Components
- ASTM A351-2010, Castings, Austenitic, for Pressure-Containing Parts
- ASTM A352-2006, Steel Castings, Ferritic and Martensitic, for Pressure-Containing Parts, Suitable for Low-Temperature Service
- ASTM A354-2007a, Quenched and Tempered Alloy Steel Bolts, Studs, and Other Externally Threaded Fasteners
- ASTM A387-2010, Pressure Vessel Plates, Alloy Steel, Chromium-Molybdenum
- ASTM A449-2010, Hex Cap Screws, Bolts and Studs, Steel, Heat Treated, 120/105/90 ksi Minimum Tensile Strength, General Use
- ASTM A453-2010, High Temperature Bolting, With Expansion Coefficients Comparable to Austenitic Stainless Steels
- ASTM A515-2010, Pressure Vessel Plates, Carbon Steel, for Intermediate- and Higher-Temperature Service
- ASTM A516-2010, Pressure Vessel Plates, Carbon Steel, for Moderate- and Lower-Temperature Service

ASTM A537-2008, Pressure Vessel Plates, Heat-Treated, Carbon-Manganese-Silicon Steel

ASTM A540-2010a, Alloy-Steel Bolting for Special Applications

ASTM E29-2008, Using Significant Digits in Test Data to Determine Conformance With Specifications

Publisher: American Society for Testing and Materials (ASTM International), 100 Barr Harbor Drive, P.O. Box C700, West Conshohocken, PA 19428-2959 (www.astm.org)

ISO 9000:2000, Quality management systems — Fundamentals and vocabulary¹

ISO 9001:2000, Quality management systems — Requirements¹

ISO 9004:2009, Managing for the sustained success of an organization — A quality management approach¹

Publisher: International Organization for Standardization (ISO), Central Secretariat, Chemin de Blandonnet 8, Case Postale 401, 1214 Vernier, Geneva, Switzerland (www.iso.org)

MSS SP-9-2008, Spot-Facing for Bronze, Iron, and Steel Flanges

MSS SP-25-2008, Standard Marking System for Valves, Fittings, Flanges, and Unions

MSS SP-44-2010, Steel Pipe Line Flanges

MSS SP-45-2003(R2008), Bypass and Drain Connections

MSS SP-61-2009, Pressure Testing of Valves

Publisher: Manufacturers Standardization Society of the Valve and Fittings Industry, Inc. (MSS), 127 Park Street, NE, Vienna, VA 22180 (www.msshq.org)

¹ May also be obtained from the American National Standards Institute (ANSI), 25 West 43rd Street, New York, NY 10036.

NONMANDATORY APPENDIX A

METHODS USED FOR ESTABLISHING PRESSURE–TEMPERATURE RATINGS

A-1 GENERAL CONSIDERATIONS

A-1.1 Introduction

Pressure–temperature ratings for this Standard have been determined by the procedures described in this Appendix. These procedures are counterpart to those identified in ASME B16.34. The primary considerations in establishing ratings are component dimensions and material properties to sustain pressure and other loads.¹ Other considerations affecting or limiting the ratings include

- (a) stresses in flanges resulting from bolt-up necessary to maintain a gasket seal
- (b) distortion of flanges and flanged fittings due to loads transmitted through attached piping
- (c) limitations applying primarily to flanged components (e.g., valves), but imposed also on flanges in order to preserve compatible ratings

A-1.2 Material Properties

The pressure–temperature rating method uses allowable stress, ultimate tensile strength, and yield strength values from ASME Boiler and Pressure Vessel Code, Section II, Part D. For materials listed herein that have ratings either at temperature values that are above those shown in a referenced Code Section or that are not listed in any of the referenced Code Sections, the allowable stress, ultimate tensile strength, and yield strength data have been provided directly by the ASME Boiler and Pressure Vessel Subcommittee on Materials.

A-1.3 Material Groups

Materials are grouped in [Table 1](#) based on identical or closely matched allowable stress and yield strength values. When these values are not identical for each material listed, the lowest value has been used. Note that material groups in this Standard are not numbered consecutively. The unlisted numbers, numbers that are not part of this Standard, may be found in the materials tables of ASME B16.34.

¹This method is appropriate for materials listed in [Table 1](#). It may not be appropriate for other materials.

A-2 PRESSURE–TEMPERATURE RATING METHOD

A-2.1 Rating Equation Class 300 and Higher

Pressure–temperature ratings for Class 300 and higher flanges manufactured from materials listed in [Table 1](#) were established by [eq. \(A-1\)](#).

$$p_t = \frac{C_1 S_1}{8 \cdot 750} P_r \leq p_c \quad (\text{A-1})$$

- $C_1 = 10$ when S_1 is expressed in MPa units and the resultant p_t will be in bar units ($C_1 = 1$ when S_1 is expressed in psi units and the resultant p_t will be in psi units)
- $p_c =$ ceiling pressure, bar (psi), at temperature T as specified in [para. A-3](#)
- $P_r =$ pressure rating class index. For all designations Class 300 and above, P_r is equal to the class designation (e.g., for Class 300, $P_r = 300$). For Classes 75 and 150, see [para. A-2.4](#).
- $p_t =$ rated working pressure, bar (psi), for the specified material at temperature T
- $S_1 =$ selected stress, MPa (psi) for the specified material at temperature T . The value of S_1 shall be established as described in [paras. A-2.2, A-2.3, and A-2.4](#).

A-2.2 Ratings for Group 1 Materials

The selected stress for Group 1 materials in [Table 1](#) is determined as follows:

- (a) At temperatures below the creep range, S_1 shall be equal to or less than
 - (1) 60% of the specified minimum yield strength at 38°C (100°F)
 - (2) 60% of the yield strength at temperature T
 - (3) 1.25 times 25% of the ultimate tensile strength value at temperature T , as listed in ASME Boiler and Pressure Vessel Code, Section II, Part D, for either Section I or Section VIII, Division 1
- (b) At temperatures in the creep range, the value of S_1 shall be the allowable stress at temperature T , as listed in ASME Boiler and Pressure Vessel Code, Section II, Part D, for either Section I or Section VIII, Division 1. However, it

shall not exceed 60% of the listed yield strength at temperature.

(c) In no case shall the selected stress value increase with increasing temperature.

(d) The creep range is considered to be at temperatures in excess of 370°C (700°F) for Group 1 materials.

(e) When the allowable stresses listed for the referenced ASME Boiler and Pressure Vessel Code Section show a higher and lower value for allowable stress and the higher value is noted to the effect that these stress values exceed two-thirds of the yield strength at temperature, then the lower shall be used. If lower allowable stress values do not appear and it is noted in the allowable stress table that the allowable stress values exceed two-thirds of the yield strength at temperature, then the allowable stress values used shall be determined as two-thirds of the tabulated yield strength at temperature.

(f) Yield strength shall be as listed in ASME Boiler and Pressure Vessel Code, Section II, Part D, for either Section III or Section VIII, Division 2.

(g) Allowable stress values listed in ASME Boiler and Pressure Vessel Code, Section II, Part D, for Section III, Class 2 or Class 3 values may only be used for a material not listed for either Section I or Section VIII, Division 1.

A-2.3 Method for Group 2 Materials

Pressure–temperature ratings for Class 300 and higher flanges manufactured from materials listed in Table 1, Material Group 2 are established by the method of paras. A-2.1 and A-2.2, except that in paras. A-2.2(a)(1) and A-2.2(a)(2), the 60% factor shall be changed to 70%. For Group 2 materials, the creep range is considered to be at temperatures in excess of 510°C (950°F) unless the material properties indicate that lower temperatures should be used.

A-2.4 Method for Class 75 and 150 — All Materials

Pressure–temperature ratings for Class 75 and 150 rating designations are established by the method given for the related materials in paras. A-2.1, A-2.2, and A-2.3, subject to the following exceptions:

(a) the value of P_r , the pressure class rating index, in eq. (A-1) for Class 75 shall be 57.5 and for Class 150 shall be 115

(b) the value for S_1 , the selected stress, MPa (psi), for the specific material at temperature T shall be in accordance with the requirements of either para. A-2.1 or A-2.2, as applicable

(c) the value of p_t , the rated working pressure, bar (psi), for Class 150 shall not exceed values at temperature T as given by eq. (A-2)

$$p_t \leq C_2 - C_3T \quad (\text{A-2})$$

T = material temperature, °C (°F)

For Class 150

C_2 = 21.41 with T expressed in °C, the resultant p_t will be in bar units

= 320 with T expressed in °F, the resultant p_t will be in psi units

C_3 = 0.03724 with T expressed in °C, the resultant p_t will be in bar units

= 0.3 with T expressed in °F, the resultant p_t will be in psi units

For Class 75

C_2 = 10.71 with T expressed in °C, the resultant p_t will be in bar units

= 160 with T expressed in °F, the resultant p_t will be in psi units

C_3 = 0.01862 with T expressed in °C, the resultant p_t will be in bar units

= 0.15 with T expressed in °F, the resultant p_t will be in psi units

The value of T in eq. (A-2) shall not exceed 538°C (1,000°F). For values of T less than 38°C (100°F), use T equal to 38°C (100°F) in eq. (A-2).

A-3 MAXIMUM RATINGS

The rules for establishing pressure–temperature ratings include consideration of ceiling pressures that effectively set limits on the selected stress. The ceiling pressure–temperature values set an upper bound for high strength materials and are imposed to limit deflection. Ceiling pressure values are listed in Tables A-1 and A-2. Ratings in excess of these ceiling values are not permitted under this Standard.

Table A-1 Rating Ceiling Values in bar

Temperature, °C	Ceiling Pressure by Classes, bar					
	75	150	300	400	600	900
-29 to 38	10.0	20.0	51.7	68.9	103.4	155.1
50	9.8	19.5	51.7	68.9	103.4	155.1
100	8.9	17.7	51.5	68.7	103.0	154.6
150	7.9	15.8	50.3	66.8	100.3	150.6
200	6.9	13.8	48.6	64.8	97.2	145.8
250	6.1	12.1	46.3	61.7	92.7	139.0
300	5.1	10.2	42.9	57.0	85.7	128.6
325	4.7	9.3	41.4	55.0	82.6	124.0
350	4.2	8.4	40.3	53.6	80.4	120.7
375	[Note (1)]	7.4	38.9	51.6	77.6	116.5
400	...	6.5	36.5	48.9	73.3	109.8
425	...	5.5	35.2	46.5	70.0	105.1
450	...	4.6	33.7	45.1	67.7	101.4
475	...	3.7	31.7	42.3	63.4	95.1
500	...	2.8	28.2	37.6	56.5	84.7
525	...	1.9	25.8	34.4	51.6	77.4
538	...	1.4	25.2	33.4	50.0	75.2
550	...	[Note (2)]	25.0	33.3	49.8	74.8
575	24.0	31.9	47.9	71.8
600	21.6	28.6	42.9	64.2
625	18.3	24.3	36.6	54.9
650	14.1	18.9	28.1	42.5
675	12.4	16.9	25.2	37.6
700	10.1	13.4	20.0	29.8
725	7.9	10.5	15.4	23.2
750	5.9	7.9	11.7	17.6
775	4.6	6.2	9.0	13.7
800	3.5	4.8	7.0	10.5
816	2.8	3.8	5.9	8.6

NOTES:

- (1) Ratings for Class 75 terminate at 350°C.
(2) Ratings for Class 150 terminate at 538°C.

Table A-2 Rating Ceiling Values in psig

Temperature, °F	Ceiling Pressure by Classes, psig					
	75	150	300	400	600	900
-20 to 100	145	290	750	1,000	1,500	2,250
200	130	260	750	1,000	1,500	2,250
300	115	230	730	970	1,455	2,185
400	100	200	705	940	1,410	2,115
500	85	170	665	885	1,330	1,995
600	70	140	605	805	1,210	1,815
650	60	125	590	785	1,175	1,765
700	[Note (1)]	110	570	755	1,135	1,705
750	...	95	530	710	1,065	1,595
800	...	80	510	675	1,015	1,525
850	...	65	485	650	975	1,460
900	...	50	450	600	900	1,350
950	...	35	385	515	775	1,160
1,000	...	20	365	485	725	1,090
1,050	...	[Note (2)]	360	480	720	1,080
1,100	325	430	645	965
1,150	275	365	550	825
1,200	205	275	410	620
1,250	180	245	365	545
1,300	140	185	275	410
1,350	105	140	205	310
1,400	75	100	150	225
1,450	60	80	115	175
1,500	40	55	85	125

NOTES:

- (1) Ratings for Class 75 terminate at 650°F.
(2) Ratings for Class 150 terminate at 1,000°F.

NONMANDATORY APPENDIX B GASKETS (OTHER THAN RING-JOINT)

B-1 GASKET MATERIALS AND CONSTRUCTION













Classification of gasket materials and types is shown in [Table B-1](#). Other gaskets that result in no increase in bolt loads or flange moment over those resulting from the gaskets included in the respective groups may be used. See [para. 5.4](#).

B-2 GASKET DIMENSIONS

Reference to a dimensional standard for gaskets, such as ASME B16.21, is recommended. In any case, selected dimensions should be based on the type of gasket and

its characteristics. These characteristics include density, flexibility, compatibility with the fluid being contained, and gasket compression needed to maintain sealing. Consideration should be given to the need for a “pocket” at the gasket inside diameter (between the flange facings) or of intrusion of the gasket into the flange bore. Consideration should also be given to the effects that the contained fluid may have upon the gasket, including damage that may result from partial disintegration of the gasket material.

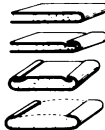
Table B-1 Gasket Groups and Typical Materials

Gasket Group Number	Gasket Material	Sketches
Ia	Self-energizing types: O-rings, metallic, elastomer, other gasket types considered self-sealing	...
	Elastomer without fabric	
	Compressed sheet suitable for the operating conditions	
	Fluoropolymer, elastomer with cotton fabric insertion	
	Elastomer with or without wire reinforcement	
	Vegetable fiber	
Ib	Spiral-wound metal, with nonmetallic filler	
	Corrugated aluminum, copper or copper alloy or corrugated aluminum, copper or copper alloy double jacketed with nonmetallic filler	
	Corrugated aluminum, copper, or brass	
IIa and IIb	Corrugated metal or corrugated metal double jacketed with nonmetallic filler	
	Corrugated metal	
	Flat metal jacketed with nonmetallic filler	
	Grooved metal	
IIIa and IIIb	Solid flat metal	
	Ring-joint	...

NONMANDATORY APPENDIX C QUALITY SYSTEM PROGRAM

The products manufactured in accordance with this Standard shall be produced under a quality system program following the principles of an appropriate standard from the ISO 9000 series.¹ A determination of the need for registration and/or certification of the product manufacturer's quality system program by an independent organization shall be the responsibility of the manufacturer. The detailed documentation demon-

strating program compliance shall be available to the purchaser at the manufacturer's facility. A written summary description of the program utilized by the product manufacturer shall be available to the purchaser upon request. The product manufacturer is defined as the entity whose name or trademark appears on the product in accordance with the marking or identification requirements of this Standard.

¹ The series is also available from the American National Standards Institute (ANSI) and the American Society for Quality (ASQ) as American National Standards that are identified by the prefix "Q" replacing the prefix "ISO." Each standard of the series is listed under References in [Mandatory Appendix I](#).

NONMANDATORY APPENDIX D

METHOD FOR CALCULATING BOLT LENGTHS¹

(20)

The following equations were used in establishing dimension L as listed in various dimensional tables:

$$L_{CSB} = A + n$$

$$L_{CMB} = B + n$$

where

$A = 2(t_f + t + d) + G + F$ (i.e., stud bolt length exclusive of negative length tolerance, n)

$B = 2(t_f + t) + d + G + F + p$ (i.e., machine bolt length exclusive of negative tolerance, n)

d = heavy nut thickness (equals nominal bolt diameter, see ASME B18.2.2)

F = total height of facings or depth of ring joint groove for both flanges (see [Table D-1](#))

G = 3.0 mm (0.12 in.) gasket thickness for raised face, approximate distance between ring joint flanges listed in [Table 5](#) ([Table 5C](#)).

L_{CMB} = calculated machine bolt length as measured from underside of head to end of point

L_{CSB} = calculated stud bolt length (effective thread length, excluding end points)

L_{SSB} = specified stud bolt length (effective thread length, excluding end points), which is L_{CSB} rounded off to the nearest 5 mm (0.25 in.) increment (see [Figure D-1](#))

n = negative tolerance on bolt length (see [Table D-2](#))

t = plus tolerance for flange thickness (see [para. 7.4](#))

t_f = minimum flange thickness (see applicable dimensional tables)

Table D-1 F Values

Class	Total Height of Facings or Depth of Ring Joint Groove for Both Flanges, F , mm (in.)		
	Type of Flange Facing		
	2-mm (0.06-in.) Raised	7-mm (0.25-in.) Raised	Ring Joint
150 and 300	4 mm (0.12)	14 mm (0.50)	2 × groove depth
400 to 2500	4 mm (0.12)	14 mm (0.50)	2 × groove depth

¹The equations used in this Appendix are for calculated bolt lengths established to ensure full thread engagement of heavy hexagon nuts when worst case tolerances occur on all relevant dimensions of the flanged joint. The use of shorter bolt lengths is acceptable provided that full thread engagement is obtained at assembly (see [para. 6.5.2](#)).

Figure D-1 Specified Stud Bolt Length

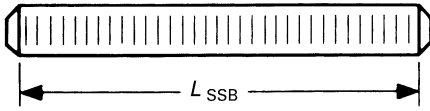

Table D-2 n Values for Stud Bolt Length, A

Negative Tolerance on Bolt Lengths,	
n , mm (in.)	Length, mm (in.)
1.5 (0.06)	≤ 305 (≤ 12)
3.0 (0.12)	> 305 (> 12), ≤ 460 (≤ 18)
7.0 (0.25)	> 460 (> 18)

ASME B16.47-2020

ISBN 978-0-7918-7381-6

